



APPLICATION OF UPFCS DEVICES FOR DAMPING OF POWER SYSTEM OSCILLATIONS

GABALLAH KHALF MOHAMED , AHMED A. HOSSAM ELDIN

Alexandria Electricity Distribution Company, Egypt ,
Prof. Dr., Department of Electrical Engineering, Alexandria university, Egypt,
E-mail: Gaballah2009@yahoo.co.uk , hossamudn2009@yahoo.com

ABSTRACT

This paper describes an adaptive tuning of parameters of a power oscillation damping (POD) controller for FACTS devices. The FACTS devices considered here are the Thyristor Controlled Series Compensator (TCSC) and the Unified Power Flow Controller (UPFC). A residue method is applied to the linearized power system model to determine the best sitting for FACTS devices as well as for the selection of measured signals. Information available from a higher control level, e.g. from a wide-area monitoring and control platform, is used for a fine tuning of the POD controller in case of changing operating conditions.

Keywords : *TCSC, UPFC, Power System Oscillations, Adaptive Control, Damping Controller Design.*

1. INTRODUCTION

Satisfactory damping of power oscillations is an important issue addressed when dealing with the rotor angle stability of power systems. This phenomenon is well known and observable especially when a fault occurs. To improve the damping of oscillations in power systems, supplementary control laws can be applied to existing devices. These supplementary actions are referred to as power oscillation damping (POD) control. In this work, POD control has been applied to two FACTS devices, TCSC and UPFC. The design method utilizes the residue approach, see e.g. [1]. The presented approach solves the optimal sitting of the FACTS as well as selection of the proper feedback signals and the controller design problem. In case of contingencies, changed operating conditions can cause poorly damped or even unstable oscillations since the set of controller parameters yielding satisfactory damping for one operating condition may no longer be valid for another one. In this case, an advantage can be taken from the wide area monitoring platform, [3], to re-tune the POD controller's parameters. A lately developed algorithm for on-line detection of electromechanical oscillations based on Kalman filtering techniques has been employed [2]. It gives the information about the actual dominant oscillatory modes with respect to the frequency and damping as well as about the amplitude of the oscillation obtained through on-line analysis of

global signals measured at the appropriate place in the power system. This has further been used as a basis for the fine adaptive tuning of the POD parameters.

2. NOTATION

The notation used throughout the paper is stated below.

Indexes:

- A the state space matrix
- B and C are the column-vector input matrix and the row-vector output matrix
- λ_i the i-th eigenvalue of the state matrix A
- ξ damping ratio
- ϕ and ψ the diagonal matrix of eigenvalues and matrices of right and left eigenvectors
- K is a positive constant gain (the controller gain)
- $H_1(s)$ is the transfer function of the washout and lead-lag blocks
- T_w The washout time constant
- G(s) The open loop transfer function of a SISO (single input single output) system
- $\Delta \lambda_i$ movement of an eigenvalue
- R_i the residue
- arg(R_i) denotes phase angle of the residue R_i

ω_1 is the frequency of the mode of oscillation in rad/sec,
 m_c is the number of compensation stages
 ΔP The active power deviation
 ΔQ The reactive power deviation
 Δr The changes of the UPFC injected series voltage magnitude
 $\Delta \gamma$ The changes of the UPFC injected series angle

$$B' = \phi^{-1} B \quad (4)$$

$$C' = C \phi$$

The mode is uncontrollable if the corresponding row of the matrix B' is zero. The mode is unobservable if the corresponding column of the matrix C' is zero. If a mode is either uncontrollable or unobservable, feedback between the output and the input will have no effect on the mode. The open loop transfer function of a SISO (single input single output) system is:

$$G(S) = \frac{\Delta y(s)}{\Delta u(s)} = C (sI - A)^{-1} B \quad (5)$$

$G(s)$ can be expanded in partial fractions of the Laplace transform of y in terms of C, B , matrices and the right and left eigenvectors as:

$$G(S) = \sum_{i=1}^N \frac{C \phi_i \psi_i B}{(S - \lambda_i)} \quad (6)$$

$$G(S) = \sum_{i=1}^N \frac{R_i}{(S - \lambda_i)}$$

3. PROBLEM FORMULATION

3.1. THE RESIDUE METHOD

In order to identify local and inter area modes of a multi machine system, the total linearized system model including FACTS devices can be represented by following equation:

$$\begin{aligned} \dot{\Delta x} &= A \Delta x + B \Delta u \\ \Delta y &= C \Delta x \end{aligned} \quad (1)$$

where B and C are the column-vector input matrix and the row-vector output matrix, respectively. Let $\lambda_i = \sigma_i + j \omega_i$ be the i -th eigenvalue of the state matrix A . The real part of the eigenvalues gives the damping, and the imaginary part gives the frequency of oscillation. The relative damping ratio is given by:

$$\xi = \frac{-\sigma_i}{\sqrt{\sigma_i^2 + \omega_i^2}} \quad (2)$$

The critical oscillatory modes considered here are those having damping ratio less than 3%. If the state space matrix A has n distinct eigenvalues, Φ and ψ below are the diagonal matrix of eigenvalues and matrices of right and left eigenvectors, respectively:

$$\begin{aligned} A \phi &= \phi A \\ \psi A &= A \psi \\ \psi &= \phi^{-1} \end{aligned} \quad (3)$$

In order to modify a mode of oscillation by feedback, the chosen input must excite the mode and it must also be visible in the chosen output. The measures of those two properties are the controllability and observability, respectively. The modal controllability and modal observability matrices are defined as follows:

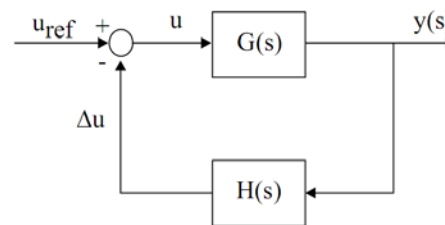

Fig. 1. Closed-loop system with POD control

Fig. 1 shows a system $G(s)$ equipped with a feedback control $H(s)$. When applying the feedback control, eigenvalues of the initial system $G(s)$ are changed. It can be proved [1], that when the feedback control is applied, movement of an eigenvalue is calculated by:

$$\Delta \lambda_i = R_i H(\lambda_i) \quad (7)$$

It can be observed from (7) that the shift of the eigenvalue caused by a controller is proportional to the magnitude of the residue. The change of eigenvalue must be directed towards the left half complex plane for optimal damping improvement. For a certain mode to be controlled, a same type of feedback control $H(s)$, regardless of its structure and parameters, is tried out at different locations. For the mode of the interest, the residues at tried locations are calculated. The largest residue

indicates the most effective location to apply the feedback control.

3.2. FACTS POD CONTROLLER DESIGN APPROACH

In order to shift the real component of i to the left, FACTS POD controller is employed. That movement can be achieved with a transfer function consisting of an amplification block, a wash-out block and m_c stages of lead-lag blocks. We adapt the structure of POD controller given in [1] and [6], i.e. the transfer function of the FACTS POD controller is:

$$H(S) = K \left(\frac{1}{1+sT_m} \right) \left(\frac{sT_w}{1+sT_w} \right) \left(\frac{1+sT_{lead}}{1+sT_{lag}} \right)^{m_c} = KH_1(S) \quad (8)$$

where K is a positive constant gain, and $H_1(s)$ is the transfer function of the washout and lead-lag blocks. The washout time constant, T_w , is usually equal to 5-10 s. The lead – lag parameters can be determined using the following equations:

$$\begin{aligned} \varphi_{comp} &= 180^\circ - \arg(R_i) \\ \alpha_C &= \frac{T_{lead}}{T_{lag}} = \frac{1 - \sin\left(\frac{\varphi_{comp}}{m_C}\right)}{1 + \sin\left(\frac{\varphi_{comp}}{m_C}\right)} \end{aligned} \quad (9)$$

$$T_{lag} = \frac{1}{\omega_i \sqrt{\alpha_C}}$$

$$T_{lead} = \alpha_C T_{lag}$$

Where $\arg(R_i)$ denotes phase angle of the residue R_i , ω_i is the frequency of the mode of oscillation in rad/sec, m_c is the number if compensation stages (usually $m_c = 2$). The controller gain K is computed as a function of the desired eigenvalue location $\lambda_{i,des}$ according to Equation 7:

$$K = \left| \frac{\lambda_{i,des} - \lambda_i}{R_i H_i(\lambda_i)} \right| \quad (10)$$

4. CASE STUDY

The linearized power system dynamics can be represented by an open-loop transfer function $G(s)$. Variable y is used by the POD controller as an input signal, variable u is where the control is fed back, see Fig. 1. Since the FACTS devices are located in transmission systems, local input signals like power deviation ΔP , bus voltages or bus currents, are always preferable. As in case of choosing the feedback signal, the optimal sitting of the FACTS device is also very important, since a larger residue results in a larger change of the corresponding oscillatory mode, (7).

A one-line diagram of the New England test system is given in the Fig. 2. The power flow data for this system can be found in [4]; the corresponding dynamic data for generators and exciters were chosen from [5]. TCSC and UPFC used in the simulations are modeled using the current injection model, [7], [8]. To find the best sitting for the TCSC and UPFC, different location in the test system are tested.

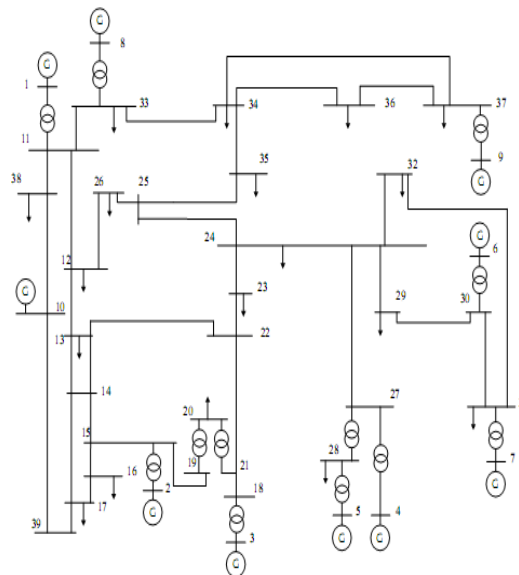

Fig. 2. System configuration for the case study

Residues associated with critical mode are calculated using the transfer function between the TCSC active power deviation ΔP and the TCSC input, that is control variable as well, characterized by the compensation degree Δk_c , i.e. the compensation in p.u. of the line reactance. For the



UPFC the residues are calculated between active and reactive power deviations ΔP and ΔQ individually, and the UPFC inputs (control variables), which are the changes of the UPFC injected series voltage magnitude and angle, Δr and $\Delta \gamma$. Tables I and II show the numerical results of sitting TCSC and UPFC, respectively.

Mode residues, R_i , of the transfer function $\Delta P/\Delta k_c$	
line 34-37	0.4508
line 34-36	0.2331
line 36-37	0.2043
line 24-25	0.1462
line 24-27	0.1007
line 25-35	0.0698
line 11-12	0.0545
line 33-34	0.0365
line 31-32	0.0307
line 24-29	0.0245
line 13-22	0.0061
line 14-15	0.0004
line 23-24	0.0003

TABLE I SITING INDICES OF TCSC

Mode residues, R_i , of the different transfer functions				
	$\Delta P/\Delta r$ ($\gamma = \gamma_0$)	$\Delta P/\Delta \gamma$ ($r = r_0$)	$\Delta Q/\Delta r$ ($\gamma = \gamma_0$)	$\Delta Q/\Delta \gamma$ ($r = r_0$)
line 34-36	5.1343	1.7122	1.2500	0.0720
line 34-37	4.8847	1.7724	1.2271	0.0794
line 25-35	4.6879	0.2936	2.3433	0.1252
line 36-37	3.9875	4.6394	0.2512	1.0076
line 24-25	2.7188	0.1016	1.5311	0.0930
line 33-34	2.3226	0.3797	1.2143	0.0986
line 24-27	1.6978	1.8707	0.5854	0.4276
line 24-29	0.5309	0.6053	0.2174	0.1519
line 14-15	0.4855	0.5554	0.1983	0.0782
line 11-12	0.2595	0.1274	0.2087	0.1380
line 23-24	0.1575	0.1447	0.0201	0.0118
line 13-22	0.1154	0.2474	0.0412	0.0411
line 31-32	0.0093	0.1793	0.0038	0.0354

TABLE II SITING INDICES OF UPFC

The active power deviation ΔP is used as the input signal for the TCSC controller and active and

reactive power deviations ΔP and ΔQ , as the input signals for the UPFC controller.

4.1. TCSC

The uncontrolled system, Fig.2, has one critical oscillatory mode characterized by $\lambda = -0.0784 \pm j 5.3677$ with damping ratio $\xi = 1.46\%$. According to Table I, the line 34-37 has the largest residue and therefore the most effective location to apply the feedback control. Using the method presented above, POD controller parameters are calculated in order to shift the real part of the oscillatory mode, to the left half complex plane. The obtained transfer function for the TCSC POD controller is :

$$H(S) = 5.89 \left(\frac{1}{0.1s + 1} \right) \left(\frac{10s}{10s + 1} \right) \left(\frac{0.0695s + 1}{0.5042s + 1} \right)^2$$

In order to check controller ability to stabilize the system, the fault is applied in the line 34-36. The fault is cleared after 100 ms by opening the faulted line. The problem with a set of fixed controller parameters arises when the system topology is changed.

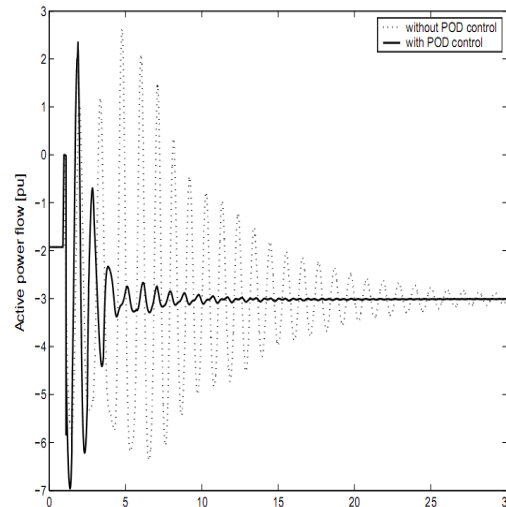

Fig. 3. Active power flow in the controlled line 34-37 with and without damping control after three phase fault is applied to line 34-36 cleared after 100ms.

A set of POD parameters that gives satisfactory damping for one operating point does not have to work for another operating point at all. In such cases, the retuning of POD parameters is required. One solution of this problem is to re-tune the

controller parameters for every new operating point based on a complete set of the model parameters, see Fig. 4. The disadvantage of this approach is the necessity of knowing all power system's data and performing on-line linearization for the new operating point. In Figure 5, direct comparison between the active power flow response of the system to the fault with old POD parameters, and with newly calculated POD parameters is shown.

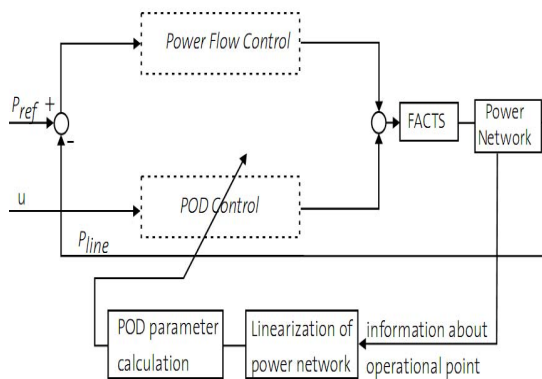

Fig. 4. POD controller tuning, method 1, general form

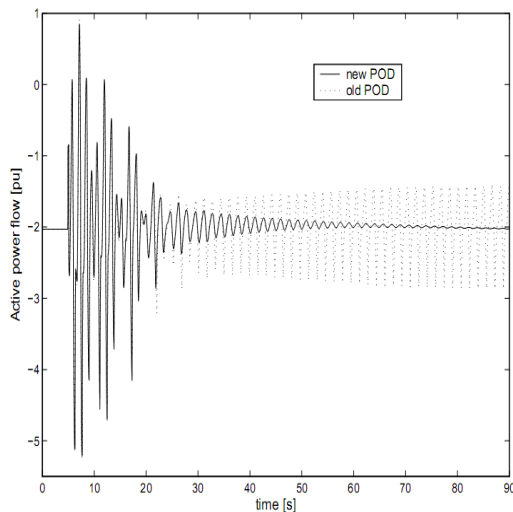

Fig. 5. Active power flow in controlled line 34-37 after three phase fault applied to line 24-25 with line 33-34 out of service.

Another possibility for re-tuning POD parameters is an adaptive on-line tuning, see Fig. 6 and 7, based on automatic detection of oscillations in power systems using dynamic data such as currents, voltages and angle differences measured across

transmission lines, [2]. They are provided on-line by phasor measurement units.

The on-line collected measured data are subject to a further evaluation with the objective to estimate dominant modes (frequencies and damping) during any operation of the power system. This information is used then to up-date the POD parameters. The POD gain is a function of the frequency and the damping, (10), whereas time constants, T_{lead} and T_{lag} are functions only of the frequency, (9). In this work (where adaptive control is derived from a monitoring algorithm where only the dominant frequency and damping are known, see [2]), one assumes that the mode residue remains unchanged (since no information about the angle of compensation is available for an up-date) and one only up-dates T_{lead} and T_{lag} according to (9). A relatively simple and powerful adaptive controller tuning has been achieved in considered test systems using this approach. Note that assuming an unchanged dominant residue for two (or more) different operating points means in words that the controller designer believes in fixed proper selection of the measured feedback signal and fixed proper location of the FACTS controller for all considered operating points. Fig. 8 and 10 show the active power flow responds for two different cases. It can be seen that adaptive on-line tuning satisfies even the N-2 criterion, see the case on Fig. 10.

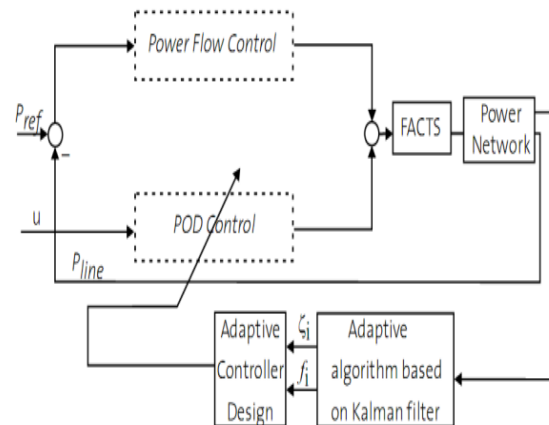

Fig. 6. POD controller tuning, method 2, general form

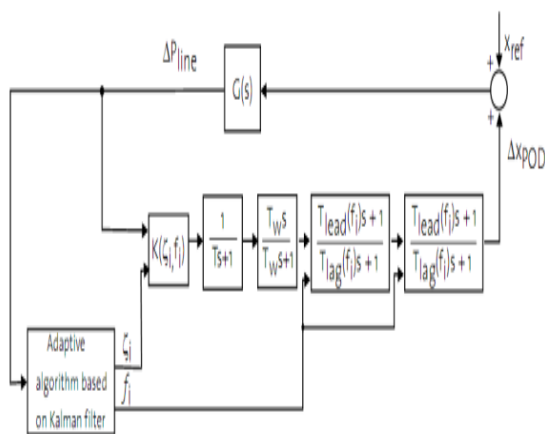

Fig. 7. POD controller tuning, method 2, detailed form

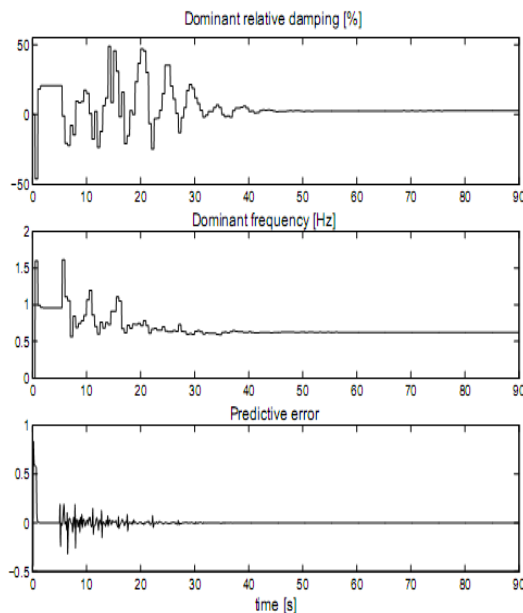

Fig. 9. Results of detection of oscillations for the case in Fig.8

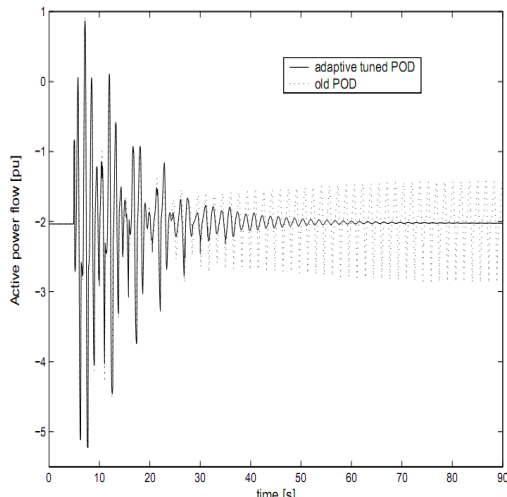

Fig. 8. Active power flow in the controlled line 34-37 after three phase fault applied to line 24-25 and with line 33-34 out of service.

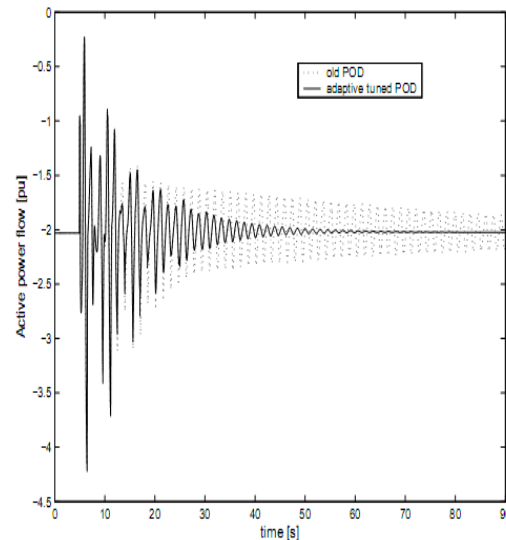

Fig. 10. Active power flow in the controlled line 34-37 after three phase fault applied to line 33-34 and with lines 31-32 and 12-26 out of service.

Fig. 9 and 11 show the results of detection of oscillations; relative damping of the dominant oscillatory mode, frequency of the dominant oscillatory mode and predictive error, which is the error between the filtered measured signal and its prediction.

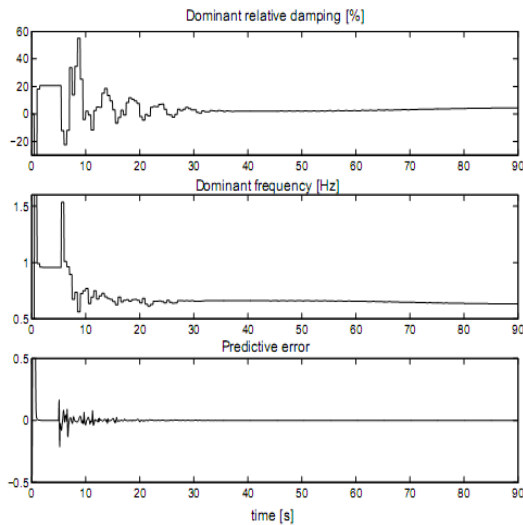

Fig. 11. Results of detection of oscillations for the case in Fig.10

4.2. UPFC

The UPFC is located subsequently in the same line as TCSC. It has two control parameters, r and the magnitude and the angle of the series injected voltage, respectively. The third variable, shunt reactive power, Q_{conv1} is inactive, so the UPFC performs the function of the series compensation. It is theoretically possible to consider four possible POD control loops. However, from Table II, where the critical mode residues of the resulting four transfer functions are calculated, one can see that Q is not a good choice for the POD controller as an input signal, since the residues of $\Delta P/\Delta r$ and $\Delta P/\Delta \gamma$ have almost always larger values than $\Delta Q/\Delta r$ and $\Delta Q/\Delta \gamma$. Based on this fact, ΔP is considered to be a better input signal than ΔQ . Hence, there are two suitable loops remaining: the first one based on the feedback signal Δr and the second one based on the signal $\Delta \gamma$. Since the residue's value for Δr as feedback signal is bigger compare to $\Delta \gamma$ only one transfer function is employed with Δr as the feedback signal. From Table II, the line 34-36 has the largest residue for the transfer function $\Delta P/\Delta r$ and therefore it would be the most effective location to apply the feedback control on r variable. The corresponding transfer function is:

$$H(S) = \frac{\Delta P}{\Delta r} = 1.2 \left(\frac{1}{0.1s + 1} \right) \left(\frac{10s}{10s + 1} \right) \left(\frac{0.094s + 1}{0.376s + 1} \right)^2$$

where the lead-lag parameters were obtained according to (9). Since the UPFC is more powerful

than the TCSC, a set of POD parameters gives very satisfactory damping for variety of operating condition so that no re-tuning is necessary when N-1 criterion is considered. Fig. 12 and Fig. 13 show two such cases.

5. CONCLUSION

This paper presented a simple adaptive tuning method based on residue approach, applied to TCSC and UPFC. It is shown that in some cases the set of TCSC POD parameters cannot stabilize the power system under all admissible operating conditions.

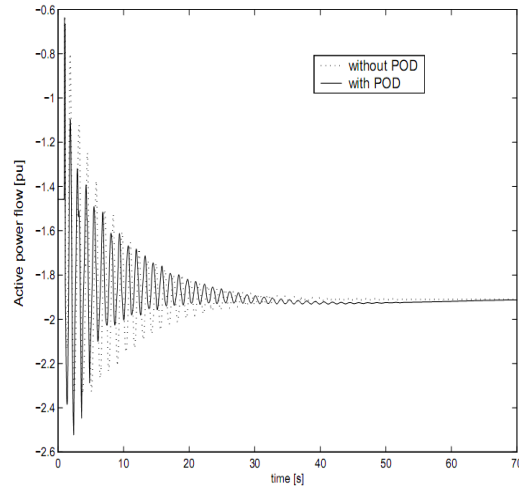

Fig. 12. Active power flow in the controlled line 34-36 after three phase fault applied to line 33-34 and with line 31-32 out of service.

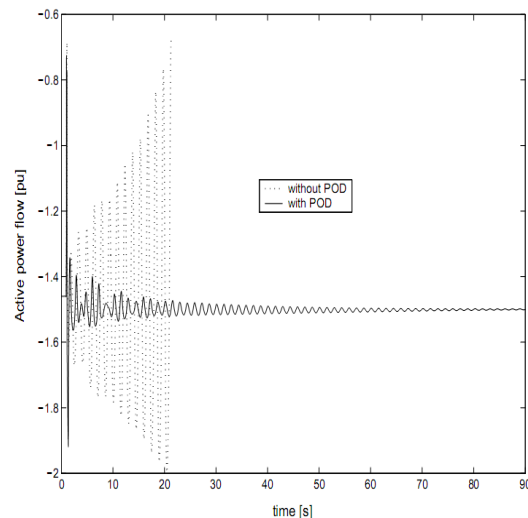

Fig. 13. Active power flow in the controlled line 34-36 after three phase fault applied to line 12-26 and with line 33-34 out of service



In this case, a re-tuning is necessary. An algorithm for detection of oscillation has been utilized to automate this procedure. In case of the more expensive UPFC, the residue approach for tuning of its POD controller gives in presented cases directly one set of parameter which works for a variety of conditions and no re-tuning is necessary.

Acknowledgment

The first author, Gaballah Khalf M. Gratefully acknowledges the support of Alexandria University for this research.

REFERENCES

- [1] M. E. Aboul-Ela, A. A. Salam, J. D. McCalley and A. A. Fouad, "Damping controller design for power system oscillations using global signals", IEEE Transactions on Power System, Vol 11, No. 2, May 1996, pp 767-773
- [2] P. Korba, M. Larsson, C. Rehtanz, "Detection of oscillations in power systems using Kalman filtering techniques", Proceedings of 2003 IEEE Conference on Control Applications, June 2003 Pages: 183 - 188 vol.1
- [3] C. Rehtanz, M. Larsson, M. Zima, M. Kaba, J. Bertsch, System for Wide Area Protection, Control and Optimisation based on Phasor Measurements, Power Systems and Communication Systems Infrastructures for the Future, Beijing, 23. - 27. September, 2002.
- [4] P. M. Anderson and A. A. Fouad, Power System Control and Stability, IEEE Press, 1994.
- [5] P. Kundur, Power System Stability and control, McGraw Hill, New York, 1994.
- [6] N. Yang, Q. Liu, J.D. McCalley, TCSC Controller Design for Damping Interarea Oscillations, IEEE Transactions on Power System, Vol 13, No.4, November 1998, pp 1304-1310
- [7] R. Sadikovic, G. Andersson, P. Korba, "Power Flow Control with FACTS Devices", World Automation Congress (WAC), Seville, 2004.
- [8] R. Sadikovic, "Damping controller design for power system oscillations", Internal report, ETH Zurich, December 2004.

AUTHOR PROFILES:

GABALLAH KHALF MOHAMED was born in Alexandria, Egypt. He obtained his Bachelor Degree from Alexandria University, Egypt, in June, 1994. He received the M.S. degree from Alexandria University, Egypt, in 2006. He has been studying at Alexandria University, Egypt, for the Ph.D. degree.

AHMED A. HOSSAM ELDIN obtained his Bachelor Degree from Alexandria University, Egypt, in 1965. He received the M.S. degree from Alexandria University, Egypt, in 1969. He received the Ph.D. Degree from, British, in 1972. He worked as Professor of Electrical Power Engineering Alexandria College, Alexandria University, Egypt, in 1974.