



GENETIC ALGORITHM BASED SCHEME FOR OPTIMIZATION OF AGC GAINS OF INERCONNECTED POWER SYSTEM

¹IBRAHEEM, ²OMVEER SINGH, ³NAMUIL HASAN

^{1,2,3}Department of Electrical Engineering, Jamia Millia Islamia University, New Delhi, India-110025

ABSTRACT

This paper demonstrates the design of an AGC scheme for an interconnected power system. The Stochastic Search Technique (SST), involving a Genetic Algorithm (GA) is used to get the optimal AGC feedback gains. A penalty function based strategy is used to satisfy transient response specifications of system frequency and power flow deviations and consequently, area control error (ACE) is minimized to zero. This proposed AGC scheme is tested on a two-area interconnected power system consisting of thermal power plants with reheat turbines. The area interconnections considered are with (i) only AC link and (ii) AC link in parallel with DC link. The dynamic response plots for various system states are obtained considering 1% load perturbation in one of the areas. The response plots achieved with proposed scheme are compared those obtained with optimal AGC regulators designed using Linear Quadratic Regulator (LQR) concept. The investigation of the system dynamic responses under load disturbance conditions reveal that proposed GA based AGC scheme yields appreciably better results as compared to those obtained with LQR concept based optimal AGC scheme. The optimal AGC gains designed using proposed scheme is more globally optimal in comparison to LQR concept based optimal AGC gains.

Index Terms—Automatic Generation Control (AGC), Stochastic Search Technique, Linear Quadratic Regulator concept (LQR), Genetic Algorithm (GA), Parallel AC/DC Links.

1. INTRODUCTION

There have been many investigations reported so far relating the operational and control problems of power systems over more than past four decades. The structural configuration of power systems has also witnessed tremendous changes due to fast developments around the world. With these changes problems associated with power system control have emerged and these have formed the basis for many technical studies, field tests, and new controller designs for the installations in power systems. In the recent years, electric power systems worldwide have grown markedly in size and complexity. Due to numerous technical and economical benefits, the interconnections between individual utilities and areas as well have increased. Therefore the efforts are always on to make the operation and control of the interconnected power systems more reliable, economic and effective [1]. The conventional control schemes employed to control the operation of these huge and complex power systems were found inadequate to cope with the desired effective, economic, reliable and

secured operation of power systems. Therefore, intelligent control schemes based on microprocessors and computers were considered for on-line monitoring and control of modern large-scale power systems in generation, transmission and distribution [2].

Undoubtedly, optimal AGC regulator designs based on LQR concept have been found superior in many aspects as compared to other conventional AGC regulator designs. The implementation of LQR based AGC schemes improve steady state error simultaneously allowing a transient response with reduced magnitude of overshoot. Moreover, an LQR based scheme adds predictive capability to the controller and is a better option. However, it suffers from the requirements of all the states for feedback which are, sometimes, not available for measurement and observation, which makes it unpopular [3-5].

The last lap of twentieth century has witnessed many research articles relating to power system control schemes based on



intelligent techniques to overcome the drawbacks of the existing schemes. Since then, a number of modified versions of these schemes have been reported in the literature [6].

Apart from fuzzy logic, neural network and artificial intelligence concepts, many power engineers have applied GA based schemes for effective and efficient operation and control of power systems. Among the various applications of intelligent concepts in power system operation and control, GA based control scheme has played a significant role in its use in automatic generation control of interconnected power systems. It circumvents the drawbacks associated with optimal AGC schemes based on LQR concept. Due to better capability of stochastic heuristic search techniques like Genetic Algorithm (GA), it has been found to be the right choice for achieving global optimum values of the gains of AGC regulators [7-8].

From the study of research papers reported in literature relating AGC of power systems, it is evident that almost all the works have been carried out considering area interconnection as AC transmission link. However, the works incorporate novel concepts relating to control aspects, power system structures and their operational and economic considerations. The transmission systems have gone through major changes in the form of transmitting electrical power at higher and higher voltage levels over the large distances. One of the major development in this area is the use of HVDC transmission systems on power scenario in India in late ninety's. Due to the inherent technical and economic merits of HVDC transmission systems over AC/EHVAC transmission systems, more DC transmission systems upto a voltage level of 765 kV were developed in 2007 and more HVDC transmission systems have been envisaged for future [9]. Therefore, it becomes necessary to incorporate the dynamics of HVDC systems while designing the AGC scheme for interconnected power systems.

The present paper is devoted to design and implantation of optimal AGC schemes using GA for optimizing the feedback gains for AGC regulators. For the sake of comparison, the optimal AGC scheme based on LQR concept are also obtained. A two-area interconnected power

system model consisting of reheat thermal plants has been selected for investigations. The area interconnections considered are AC link only and AC link in parallel with DC link. The DC link is considered to be operating in constant current control mode. The incremental power flow through turbine controllers is considered as an additional state variable in system dynamic model. The designed optimal AGC schemes are implemented in the wake of 1% load perturbations in one of the power system areas.

2. SYSTEM UNDER INVESTIGATION

The transfer function model of two area interconnected power system under consideration is shown in Fig. 1. The system dynamic equations in state space for this model can be given as:

$$d/dt (\underline{X}) = A \underline{X} + B \underline{U} + \Gamma \underline{P}_d \quad (1)$$

$$\underline{Y} = C \underline{X} \quad (2)$$

Where, A, B, C & Γ are system state, control, measurement and disturbance matrices respectively and \underline{X} , \underline{U} , \underline{Y} & \underline{P}_d are state, control, output and disturbance vectors of compatible dimensions respectively.

From the transfer function model of Fig. 1, the structure of vectors \underline{X} , \underline{U} and \underline{P}_d may be developed as follows:

System State Vector

$$[\underline{X}] = [\Delta F_1 \Delta P_{g1} \Delta P_{r1} \Delta X_{g1} \Delta F_2 \Delta P_{g2} \Delta P_{r2} \Delta X_{g2} \Delta P_{tie} \int ACE_1 dt \int ACE_2 dt]^T$$

Without DC link

$$[\underline{X}] = [\Delta F_1 \Delta P_{g1} \Delta P_{r1} \Delta X_{g1} \Delta F_2 \Delta P_{g2} \Delta P_{r2} \Delta X_{g2} \Delta P_{tie} \int ACE_1 dt \int ACE_2 dt \Delta P_{dc}]^T$$

Parallel AC/DC

link

Control Vector

$$[\underline{U}] = [\Delta P_{c1}, \Delta P_{c2}]^T$$

Disturbance Vector

$$[\underline{P}_d] = [\Delta P_{d1}, \Delta P_{d2}]^T$$

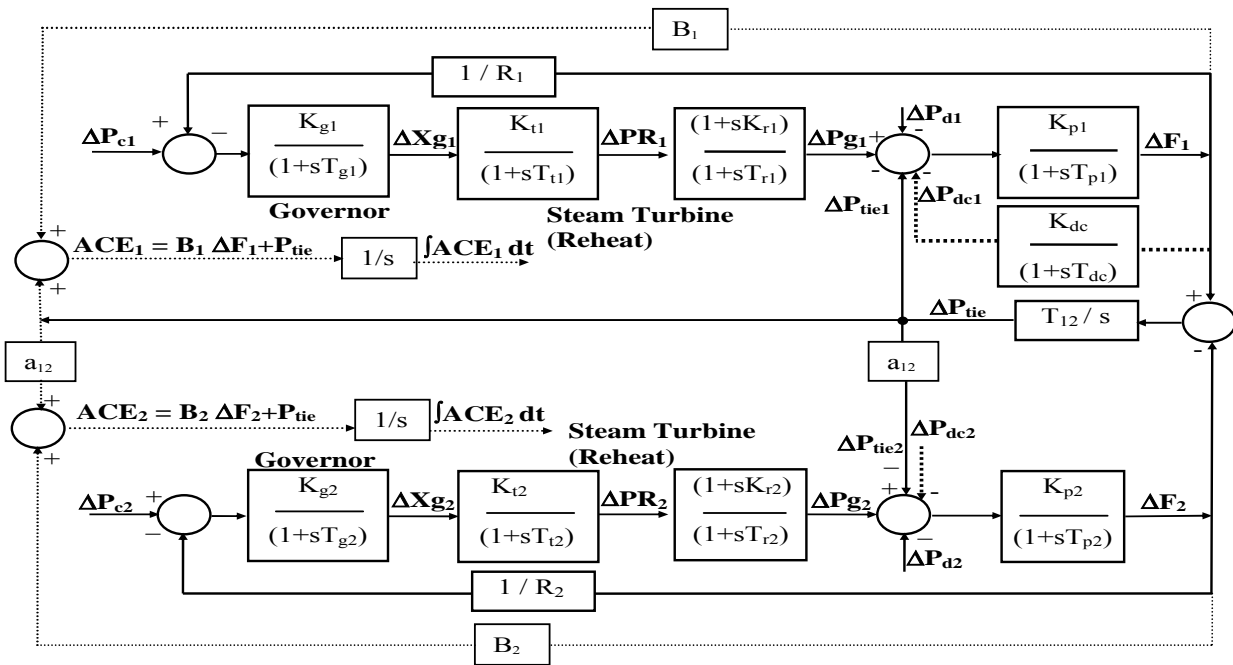

Fig.1. Transfer Function Block diagram of Power System model

System Matrices

The matrices, A, B and Γ as appeared in equations (1) and (2) can be obtained using the structures of state, control and disturbance vectors and the transfer function model representation of Fig.1. Using the numerical values of system variables as given in Appendix, the corresponding coefficient matrices are derived as;

$$B^T = \begin{bmatrix} 0 & 0 & 0 & 12.5000 & 0 & 0 & 0 & 0 & 0 & 0 & 0 \\ 0 & 0 & 0 & 0 & 0 & 0 & 0 & 12.5000 & 0 & 0 & 0 \end{bmatrix}$$

$$F^T = \begin{bmatrix} -5.9880 & 0 & 0 & 0 & 0 & 0 & 0 & 0 & 0 & 0 & 0 \\ 0 & 0 & 0 & 0 & -5.9880 & 0 & 0 & 0 & 0 & 0 & 0 \end{bmatrix}$$

$$A = \begin{bmatrix} -0.0499 & 5.9880 & 0 & 0 & 0 & 0 & 0 & 0 & -5.9880 & 0 & 0 \\ 0 & -0.1000 & -1.5667 & 1.6667 & 0 & 0 & 0 & 0 & 0 & 0 & 0 \\ 0 & 0 & -3.3333 & 3.3333 & 0 & 0 & 0 & 0 & 0 & 0 & 0 \\ -5.2083 & 0 & 0 & -12.5000 & 0 & 0 & 0 & 0 & 0 & 0 & 0 \\ 0 & 0 & 0 & -0.0499 & 5.9880 & 0 & 0 & 5.9880 & 0 & 0 & 0 \\ 0 & 0 & 0 & 0 & -0.1000 & -1.5667 & 1.6667 & 0 & 0 & 0 & 0 \\ 0 & 0 & 0 & 0 & 0 & -3.3333 & 3.3333 & 0 & 0 & 0 & 0 \\ 0 & 0 & 0 & -5.2083 & 0 & 0 & -12.5000 & 0 & 0 & 0 & 0 \\ 5.3789 & 0 & 0 & 0 & -5.3789 & 0 & 0 & 0 & 0 & 0 & 0 \\ 0.4250 & 0 & 0 & 0 & 0 & 0 & 0 & 0 & 0 & 1.0000 & 0 & 0 \\ 0 & 0 & 0 & 0 & 0.4250 & 0 & 0 & 0 & 0 & -1.0000 & 0 & 0 \end{bmatrix}$$

The appropriate modification can be done in the structure of matrix ‘A’ to consider the area interconnection as AC link in parallel with DC link in power system model. Consideration of DC link dynamic model as state variable will have the additional non-zero elements of ‘A’ matrix as;

$$A(1, 12) = -5.988, A(12, 1) = 5.0, A(12, 12) = -5.0$$

The rest of the additional elements are zero.

Design Matrices

The state cost weighting matrix ‘Q’ and control cost weighting matrix ‘R’ are selected as an identity matrix of compatible dimensions respectively.



3. THE GA CONTROL SCHEME

The GA based control scheme is designed using SST [10]. The solution string comprises of all feedback gains and is encoded as a string of real numbers. The population structure of SST is shown in the Table I. The SS heuristic employs blend crossover and a mutation operator suitable for real number representation to provide a better search capability. In the application of this concept in achieving optimal AGC gains for power system, the objective is to minimize the Integral Area Control Error ($\int ACE dt$) augmented with penalty terms corresponding to transient response specifications in the controller output, frequency and power flows in the transmission lines. The heuristic is quite general and various aspects like nonlinear, discontinuous functions and constraints are easily incorporated as per requirements [11-13]. The heuristic can be described using the following pseudo-code.

Step 1: Initialize randomly select N parent string

Step 2: For each parent i, generate m(i) children using crossover

Step 3: Employ the mutation operator with probability P_m

Step 4: Find the best child for each parent (1st level of competition)

Step 5: Select the best child as the parent for the next generation

For each family, accept the best child as the parent for next generation **if**

$$Y_1 < Y_2 \text{ OR } \exp(Y_2 - Y_1) \geq \rho$$

Step 6: Repeat Steps 7 to 10 for each family

Step 7: count = 0

Step 8: Repeat Step 9 for each child; **Goto** Step 9

Step 9: Increase count by 1, **if**

$$((Y_1 < Y_2) \text{ OR } \exp((Y_{\text{LOWEST}} - Y_1)) \geq \rho)$$

Step 10: Acceptance number of the family is equal to count (A)

Step 11: Sum up the acceptance numbers of all the families (S)

Step 12: For each ith family, calculate the number

of children to be generated in the next generation according to the following formula; $m(i) = (TC * A) / S$

Step 13: Repeat Steps 2 to 12 **until** a maximum number of iterations have been completed.

Here, Y_1 is the objective value of the best child

Y_2 is the objective value of its parent

ρ is a random number uniformly distributed between 0 and 1.

TC is total number of children generated by all the families.

The solution string comprises of all feedback gains. A real string representation is selected. Population size of 100 is taken as a compromise between exhaustive search and computational burden. A brief explanation of each step followed in the implementation of SST is presented in the ensuing paragraphs.

A. Crossover

For each parent i, mates are selected from the other parents randomly and crossover is applied to generate m(i) children. To start with, m(i) is fixed same for all the parents. This number is changed as the search progresses as explained in the subsequent steps.

B. Fitness Evaluation

The objective here is to minimize the deviation in the frequency of the two areas and the power flow deviation in the interconnected power system. The fitness function is taken as the summation of the absolute values of the three at every discrete time instant in the simulation. An optional penalty term is added to take care of the transient response specifications viz. transient response specifications on system frequency, power flows, area control error's, settling time, over shoots etc.

C. Selection

The best child (the child with minimum objective value) out of the children generated from the same parent is found. The best child then competes with its parent to survive in the next generation. If the best child is better than its parent, it is accepted as a parent in the next generation.

D. Acceptance Number

The number of children generated in the next generation is proportional to a parameter called the acceptance number. This number provides a measure of the goodness of the solutions in the vicinity of the current parent. The number is computed by sampling the search space around the current parent and counting the number of good samples out of the total samples as per steps 7 to 10 of the pseudo-code. This strategy

enables the algorithm to focus search on the better regions of the search space.

The genetic algorithm used here employs direct manipulation of the parameters. The following genetic algorithm parameters are used in the present study.

Population size: 100

Maximum no. of generations (Max Gen): 200

Crossover probability: $\exp(\text{generation}/\text{Max Gen})$

Mutation probability: 0.4

4. DISCUSSION OF RESULTS

The optimal AGC gains using LQR concept and GA based scheme are obtained considering the power system model of Fig.1. The population structure of SST is given in Table-I whereas, the optimal gains are presented in Table-II. To study the dynamic performance of the power system, the time response plots are plotted for various system states considering 1% load disturbance in one of the power system areas with the designed optimal AGC regulators. The dynamic responses of two different power system models based on different area interconnections are also obtained. The response plots are shown in Figs. 2-7. As evident from Table-I and Table II, the best child generation is 98. In single run, the proposed heuristic gives best solutions with respect to individual objectives which is the most important feature of any iterative optimization algorithm to converge rapidly to optimal solution.

From the investigations of dynamic response plots, it is inferred that the implementation of GA based optimal AGC regulator designs have resulted in an appreciable reduction in magnitude of first peak overshoot and settling time of ΔF_1 , ΔF_2 response plots as compared to that obtained with LQR concept based optimal AGC regulators. As far as the effect of incorporating DC link in parallel with AC link as area interconnection is concerned, the incorporation of DC has an ameliorated effect on system dynamic performance. The trend of settling the time response plots is smooth and faster with GA based AGC scheme. It is of the order of 3 seconds in case of both types of area interconnections as considered in the study. Moreover, settling time of dynamic response plots obtained with LQR concept based AGC regulators is more than 5 seconds.

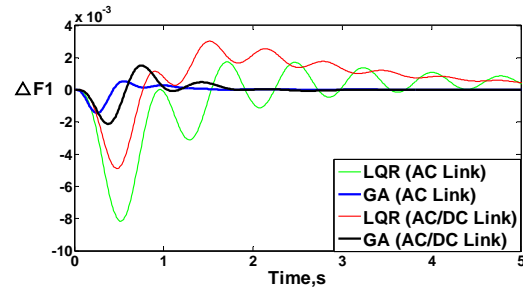

Figure 2 Dynamic Response of ΔF_1

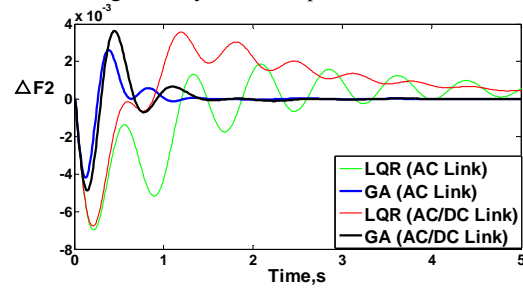

Figure 3 Dynamic Response of ΔF_2

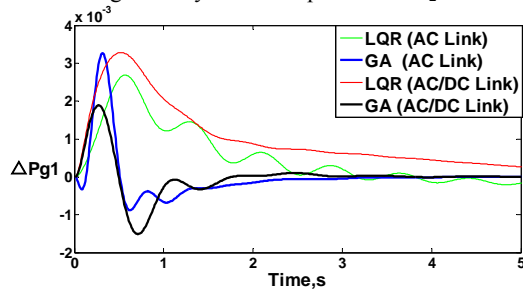

Figure 4 Dynamic Response of ΔP_{g1}

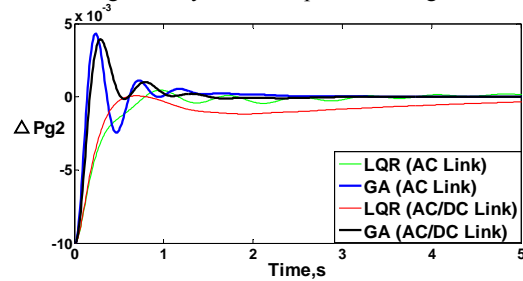

Figure 5 Dynamic Response of ΔP_{g2}

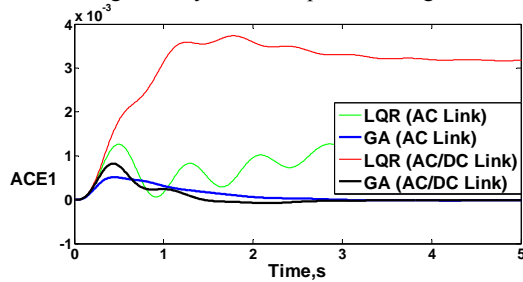

Figure 6 Dynamic Response of ΔACE_1

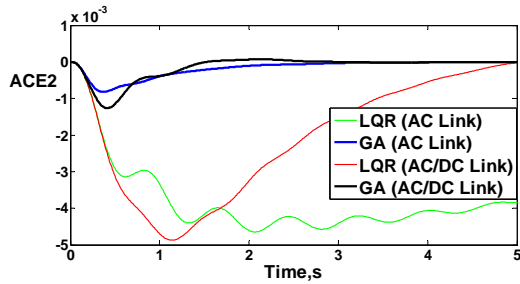

Figure 7 Dynamic Response of ΔACE_2

Family 1	Family 2	Family 3	Family n
Parent 1	Parent 2	Parent 3	Parent n
Child 11	Child 21	Child 31	Child n1
Child12	Child 22	Child 32	Child n2
-	-	-		-
-	-	-		-
-	-	-		-
Child 1w	Child 2x	Child 3y	Child nz

Table I: Population Structure of SST

Optimal AGC Regulator Designs	Optimal Feedback Gain Matrices for Power system model with area interconnection as AC link only			
	<table border="1"> <tr> <td>LQR Concept</td> <td>$\begin{bmatrix} 0.5987 & 4.2681 & -1.1493 & 0.5891 & 0.3238 & 0.4869 & -0.1835 & 0.0101 & -0.9877 & 1.0000 & -0.0000 \\ 0.3238 & 0.4869 & -0.1835 & 0.0101 & 0.5987 & 4.2681 & -1.1493 & 0.5891 & 0.9877 & -0.0000 & 1.0000 \end{bmatrix}$</td> </tr> <tr> <td>GA</td> <td>$\begin{bmatrix} -1.3307 & 0.5485 & -0.0768 & -0.2053 & 0.5307 & -2.1879 & 0.3948 & -0.4108 & -0.6127 & 4.0010 & 0.1242 \\ 2.0347 & -0.3635 & 1.4211 & 0.4547 & 6.8161 & 9.8349 & -0.7694 & -0.1652 & 0.6428 & 3.9287 & 9.8674 \end{bmatrix}$</td> </tr> </table>	LQR Concept	$\begin{bmatrix} 0.5987 & 4.2681 & -1.1493 & 0.5891 & 0.3238 & 0.4869 & -0.1835 & 0.0101 & -0.9877 & 1.0000 & -0.0000 \\ 0.3238 & 0.4869 & -0.1835 & 0.0101 & 0.5987 & 4.2681 & -1.1493 & 0.5891 & 0.9877 & -0.0000 & 1.0000 \end{bmatrix}$	GA
LQR Concept	$\begin{bmatrix} 0.5987 & 4.2681 & -1.1493 & 0.5891 & 0.3238 & 0.4869 & -0.1835 & 0.0101 & -0.9877 & 1.0000 & -0.0000 \\ 0.3238 & 0.4869 & -0.1835 & 0.0101 & 0.5987 & 4.2681 & -1.1493 & 0.5891 & 0.9877 & -0.0000 & 1.0000 \end{bmatrix}$			
GA	$\begin{bmatrix} -1.3307 & 0.5485 & -0.0768 & -0.2053 & 0.5307 & -2.1879 & 0.3948 & -0.4108 & -0.6127 & 4.0010 & 0.1242 \\ 2.0347 & -0.3635 & 1.4211 & 0.4547 & 6.8161 & 9.8349 & -0.7694 & -0.1652 & 0.6428 & 3.9287 & 9.8674 \end{bmatrix}$			
	Optimal Feedback Gain Matrices for Power system model with area interconnection as parallel AC/DC links			
LQR Concept	$\begin{bmatrix} 0.5776 & 3.4915 & -0.8795 & 0.5676 & 0.6079 & 1.7782 & -0.4960 & 0.0691 & -0.2399 & 0.7235 & 0.6904 & -0.2085 \\ 0.8725 & 1.4301 & -0.2884 & 0.0691 & 0.9489 & 4.5214 & -1.2168 & 0.5975 & 0.0432 & -0.6904 & 0.7235 & 0.4385 \end{bmatrix}$			
GA	$\begin{bmatrix} 0.5878 & 1.0092 & 0.1003 & -0.4544 & 3.0980 & 1.2087 & -0.2524 & 0.2665 & 0.2898 & 0.4861 & 2.1886 & -0.2085 \\ 1.9660 & 1.0543 & 0.1407 & -0.0694 & 0.8832 & 6.8217 & -0.3847 & -0.5716 & 0.8662 & -1.9270 & 5.0205 & 0.4385 \end{bmatrix}$			

Table II: Optimal Feedback Gains

NOMENCLATURE:

- ΔF : Incremental change in frequency
- ΔP_g : Incremental change in generator power output
- ΔP_d : Incremental change in load demand
- ΔP_c : Incremental change in load demand
- ΔX_g : Incremental change in governor valve position
- ΔP_{tie} : Incremental change in tie-line power
- T_p : Electric system time constants
- R : Speed regulation parameter, Hz/p.u.MW
- K : Integral gain constant
- T_g : Speed governor time constant of area, s
- K_r, T_r : Reheat coefficient's & reheat time's
- B : Frequency bias constant
- ACE : Area control error's

- T_t : Turbine time constants,
- K_g : Speed governor gain
- K_t : Reheat thermal turbine gain constant
- T_{12} : Synchronizing coefficient of AC tie-line
- K_{dc} : DC gain constant
- T_{dc} : Synchronizing coefficient of DC tie-line

APPENDIX:

Numerical Data for System Under consideration:

Nominal freq. = 50Hz, $B_1=B_2= 0.425$, $R_1=R_2 = 2.4$ Hz/ p.u. MW, $T_{g1} = T_{g2} = 0.08$ sec, $K_{r1} = K_{r2} = 0.5$ sec, $T_{r1} = T_{r2} = 10$ sec, $T_{i1} = T_{i2} = 0.3$ sec, $K_{p1} = K_{p2} = 120$ Hz/ p.u. MW, $T_{p1} = T_{p2} = 20$ sec, $\Delta P_{d1} = 0.02$, p.u.MW, $2\pi T_{12} = 0.545$ p.u.MW, $a_{12} = -1$, $K_{dc}=T_{dc}=1$

5. REFERENCES

- [1]. Sivanagaraju S., Sreenivasan G. "Power System Operation and Control", 1st edition Pearson Publishing Company Ltd., New Delhi, 2009.
- [2]. Moorthy P. S. R. "Power System Operation and Control," Tata Mc Graw Hill publishing Company Limited. 1984.
- [3]. O. I. Elgerd and C. Fosha, "Optimum megawatt frequency control of multi-area electric energy systems," *IEEE Trans. Power App. Syst.*, vol. PAS-89, no. 4, pp. 556-563, Apr. 1970.
- [4]. P. Kumar and Ibraheem, "Dynamic performance evaluation of 2-area interconnected power systems: A comparative study," *J. Inst. Eng.*, vol.78, pp. 199-208, 1998.
- [5]. Kothari, Nanda and Das, "Discrete mode AGC of a two area Reheat Thermal System with new Area Control Error", *IEEE Trans.*, PAS.-4(2), May 1989, 730 – 738.
- [6]. Ibraheem, Kumar, P. and Kothari, D. P. "Recent philosophies of automatic generation control strategies in power systems," *IEEE Trans. Power System*, vol. 11, no. 3, pp. 346-357, February 2005.
- [7]. Loi Lei Lai, "Intelligent system applications in power engineering" John Wiley & Sons, 1998
- [8]. Mathur H. D., "A comprehensive analysis of intelligent controllers for load frequency control," *Proc. IEEE Power India Conf.*, 2006, vol. no. 07803-9525.
- [9]. Report on "National Electricity Plan, Volume II, Transmission" Central Electricity Authority, Government of India, Ministry of Power, New Delhi, April, 2007, pp1-29.
- [10]. Alander J. T., "An indexed bibliography of genetic algorithm in power engineering," Report series 94-1, Power, 21 February 1996, ftp://ftp. Uwasa. Fi/cs/report 94-1/ga_power_bib.ps.z.
- [11]. D.B. Das, C. Patvardhan, "New multi-objective stochastic search technique for economic load dispatch" *IEE Proc.-Generation. Trans. Distri.*, Vol. 145, No. 6, November 1998
- [12]. Aditya, S. K. and Das, D. "Design of load frequency controllers using genetic algorithm for two area interconnected hydro power system," *Elect. Power Compon. Syst.*, vol. 31, no. 1, pp. 81-94, Jan. 2003.
- [13]. Nidul Sinha et al, "GA Optimized PID Controllers for Automatic Generation Control of Two Area Reheat Thermal Systems under Deregulated Environment" *DRPT-2008, Nanjing (China) 6-9 April 2008.*

BIOGRAPHIES:



Ibraheem: with the Department of Electrical Engineering, Faculty of Engineering and Technology, Jamia Millia Islamia (Central University), New Delhi, India, where he is currently a Professor of electrical

engineering. He has published a number of research papers in national/international journals and has been continuously engaged in guiding research activities at graduate/post-graduate and Ph.D. levels.

Dr. Ibraheem received a Gold Medal from the Union Ministry of Power and Energy (India) in 1998 for one of his research articles.

Omveer Singh: (B, 04 and M, 06) was born on Dec 20, 1981 in Aligarh district of Uttar Pradesh, India. He got B. Sc. Engineering in Electrical and M.Tech. Degree in System Engineering from Faculty of Engg., Dayalbagh Educational Institute (Deemed University), Agra, India.

Currently he is Research Scholar in Electrical Deptt., Faculty of Engg. And Technology, Jamia Millia Islamia University, New Delhi, India. His major field of interest includes advanced power systems, soft computing techniques.

Naimul Hasan: received his Ph.D. in Electrical Engineering from JMI (Central University), New Delhi, India. He is presently working as Faculty in Electrical Engineering at Faculty of Engineering & Technology, JMI, and New Delhi, India. His research interests include power system operation and control, security analysis, energy management.