

AN IMPROVEMENT OF SIMILARITY IN CASE BASED REASONING USING SUBJECTIVE-GENERALIZED WEIGHT FOR TRADITIONAL INDONESIAN CUISINE

¹SETYAWAN WIBISONO, ²WIWIEN HADIKURNIAWATI, ³HERNY FEBRUARIYANTI, ⁴MARDI SISWO UTOMO

^{1,2,3,4}Faculty of Information Technology, Universitas Stikubank, Semarang, Indonesia

¹setyawan@edu.unisbank.ac.id, ²wiwien@edu.unisbank.ac.id, ³hernyfeb@edu.unisbank.ac.id,

⁴mardi@edu.unisbank.ac.id

ABSTRACT

In this study, a system for providing recommendations from a traditional Indonesian food recipe consultation using the CBR (Case Based Reasoning) method was designed. A recommendation is given based on the similarity of the input in the form of ingredients for cooking compared to the ingredients for cooking from a recipe that has been stored in the database. Increasing the accuracy of the similarity value is the goal to be achieved in this study. This method used is intended to give the weight to each food-forming material, then the Dice algorithm is used to calculate the value of similarity. Weighting is determined subjectively but takes into account the principle of appropriateness in general. Test the validity of the weight value using the weighting principles in the AHP (Analytical Hierarchy Process). This makes the value of the similarity of a recipe suggestion more accurate because it considers proportional weighting of the ingredients forming the recipe.

Keywords: *consultation similarity value, CBR, weighting, Dice algorithm, AHP*

1. INTRODUCTION

The combination of geographic and cultural diversity in Indonesia has resulted in one of the most unique cuisines in the world. Each region has a different kind of food. A food ingredient can be a different culinary in other regions. Because of the humid climate and volcanic soil, tropical fruits, vegetables and spices are found in abundance. Dried spices such as coriander seeds, cardamom pods, cinnamon quills, cumin seeds, cloves and nutmeg are used every day in many dishes and each curry has a number of dried spices as well as fresh herbs. In the current global world traditional food is increasingly lost due to the influence of foreign culinary culture. Traditional cuisines are generally simple, the plentiful use of various roots, spices, grasses, and leaves adds flavor to most dishes. In Indonesia, culinary so-called traditional food is very much and varied. This makes people even confused to choose the type of cuisine to be made. Many people do not understand traditional recipes and how to cook them. A proposed system can assist a person in determining the choice of cuisine from a variety of options. The system is an expert

system to determine the cuisine. Using that, user can be helped to choose the cuisine based on the material it has. The documents are collected individually from reputable various Indonesian culinary sites such as sajiandedap.co.id, bango.co.id [1].

Case-based reasoning (CBR) is one part of the expert system in solving problems on a case-based basis. Presentation of knowledge (knowledge representation) is made in the form of cases (cases). The challenge in intelligent systems is to develop an effective modeling methodology and become a knowledge domain. New cases and old cases are compared in order to get back information that has been done before as a solution [2].

The way CBR works is by comparing new cases with old cases, if the new cases have similarities with old cases, CBR will provide answers to old cases for the new cases. If there is no match, the CBR will adapt, by entering the new case into a database of case storage, so that CBR knowledge will indirectly increase. CBR is an effective method within integrating reasoning methodology and representation of the knowledge domain. Case Based Reasoning (CBR) method

based on previous experience in old cases to understand and solve new problems. CBR collects previous cases that have similarities with new problems and then provide solutions for the new case. The problem solving of CBR is based on previous experience. CBR is an analogical reasoning method that solves problems by connecting some problems or experiences that were previously solved with problems that solves problems by connecting some problems or experiences that were previously solved with problems that have not been solved at this time. From that process an analogical conclusion is made to solve the problem [3],[4].

2. RELATED WORK

The essential assumption in case-based reasoning (CBR) is that similar cases have similar solutions. Facing a new problem, CBR takes a similar case stored on a case base and adjust it to fit the problem. Key factors affecting the retrieval performance mechanisms are representation, indexing and similarity metric. The retrieve process requires determining the key parameters to be used to match the target cases with the similar existing cases, determining the values of the key parameters of the target, and determining which of the existing cases have values of the key parameters that are similar to the target case [5].

Most of previous studies to improve the effectiveness for CBR have focused on the selection of appropriate instances and the optimization of case features and their weights. Weight can be determined in different ways. Examples include weights based on the coefficients used in regression models, weights based on the weights of the connections in equal importance, or simply based on expert opinion [6].

Case technology has been proposed for case-based reasons to improve the quality of ship inspections. In order to improve the efficiency of inspection and support new inspectors, an indexed tertiary case library's organization structure was proposed, that the K-Nearest Neighbor method to calculate the similarity between cases was used [7]. A CBR system has been proposed using a similarity knowledge base. This system called Similarity-Based Reasoning (SBR) that the knowledge encoded in the form of term measures is used to calculate the similarity of the cases. This is typically performed through k-nearest neighbor retrieval [8]. Music recommendation is a field that many researchers studied. A case-based reasoning method has been used to create a music

recommendation system. The system output is a playlist consists of music that suitable with user's context and desired mood [9],[10]. Research on bamboo species diversity has been carried out. They implement case based reasoning method in online expert system for bamboo identification [11].

There are some problems that must be solved in order to design an effective CBR system. One of them is how to determine the weight of each feature, which is known as feature weighting. The relative importance of different features is also determined by the experts. Weighting each parameter group uses weighting in the AHP method. Weighting on the AHP method was chosen because in this method there is a consistency ratio that must be met, which is less or equal to 10 percent. The consistency of this ratio makes the pairwise comparison show the importance of a parameter.

3. METHODS

3.1. Feature Weighting

This research adopted the AHP method for the knowledge domain based on the weighting feature on its parameters. The reasoning process is important for the knowledge domain. AHP is a theory of measurement through pairwise comparisons and relies on the judgments of experts to derive priority scales. The AHP method approach is a systematic technique for obtaining weighted features for parameters from the experts [12]. The advantages of AHP method are relatively easy to use, enabling rapid replacement of parameter ratings. The important of that advantage is to combine qualitative and subjective factors using psychometric scales to measure judgements. The AHP method provide methodology for measuring consistency of this judgements [13].

AHP is a theory of measurement through pairwise comparisons and relies on the judgments of experts to derive priority scales. It is these scales that measure intangibles in relative terms. The comparisons are made using a scale of absolute judgments that represents how much one element dominates another with respect to a given attribute [14]. The relative importance of two elements is rated using Saaty's 9-point scale as shown in table 1.

Table1: Scale of Relative Importances (According Saaty)

Intensity of Importance	Definition	Explanation
1	Equal importance	Two activities contribute equally to the objective
2	Weak or slight	
3	Moderate importance	Experience and judgment strongly favor one activity over another
4	Moderate plus	
5	Strong importance	Experience and judgment strongly favor one ctivity over another
6	Strong plus	
7	Very strong or demonstrated	An activity is favored very strongly over another; its dominance demonstrated in practise
8	Very, very strong	
9	Extreme importance	The evidence favoring one activity over another is of the highest possible order of affirmation
Reciprocals of above	If activity i has one of the above non zero numbers assigned to it compared to activity j, then j has the reciprocal value when compared with i	

The eigenvector method is used to calculate the relative weights of the elements in each pairwise comparison matrix. The relative weights are obtained from the following equation:

$$(A - \lambda_{\max} \times I) \times w = 0 \tag{1}$$

whereas λ_{\max} is the largest eigenvalue of matrix A. The Consistency Index (CI) and the Consistency Ratio (CR) use to verify the consistency of the comparison matrix. CI and CR are defined as follows:

$$CI = \frac{(\lambda_{\max} - n)}{n - 1} \tag{2}$$

where: CI = consistency index
 λ_{\max} = eigenvaluemaksimum
 n = size of matriks

Consistency Ratio = CR, can be calculated using the equation:

$$CR = \frac{CI}{RI} \tag{3}$$

where RI represents Saaty’s calculated random index measures for various sizes of matrix size (n). The pairwise comparison in a judgment matrix are considered to be adequately consistent if the corresponding consistency ratio (CR) is less than 10 %.

3.2. Retrieval and Similarity

The retrieval technique used in this study is the nearest neighbor technique. Nearest neighbor is an approach to find a case by calculating the closeness between new cases and old cases. The basic idea of this technique is to compare each target case attribute with the source case attributes that exist in the base case, then the comparison is calculated using the similarity function. Case retrieval is a process on a case base in finding solutions to a case by finding the closest case. For effective case taking, there must be selection criteria that are used to determine whether a case is valued according to the decision taking and the mechanism sought.

The weights on the features represent the relative importance. The most similar case is defined as the smallest distance from the feature vector representing the current new case. K nearest neighbor (KNN) is a simple algorithm, which stores all cases and classifies new cases based on similarity measure [15].

K-Nearest Neighbor is an algorithm used to find similarities in the nearest K value in the old case with the new case. Calculate the similarity between old cases and new cases using weighted euclidean distance. Euclidean distance method is used to find similarities by using two points of distance between old cases and new cases. The difference is that the weighted euclidean distance method is given a weighting value for each criterion based on the level of importance.

$$S(p, c) = \frac{(s_1 * w_1) + (s_2 * w_2) + \dots + (s_n * w_n)}{w_1 + w_2 + \dots + w_n} \tag{4}$$

whereas: S = Similarity
 p = problem
 c = case

Dice similarity is defined as twice the same number of attributes in a comparison divided by the total number of attributes in the two things being compared [16]. Dice similarity calculation can be written:

$$Dice(D, Q) = \frac{2|D \cap Q|}{|D| + |Q|} \quad (5)$$

To calculate the value of Similarity Dice in equation form, you can use equation:

$$S_{Dice} = \frac{2 \sum_{i=1}^d P_i Q_i}{\sum_{i=1}^d P_i^2 + \sum_{i=1}^d Q_i^2} \quad (6)$$

For example, two objects, *i* and *j*, which represent binary attribute vector shapes. The symbol *n* is a symbol that represents the sum of all attributes. The definition of binary similarity and distance determination are stated by Operational Taxonomic Units (OTUs as shown in Table 1) in the 2x2 table where *a* is the number of attributes where the values of *i* and *j* both exist (symbolized by 1,1), *b* is the number attribute where the values of *i* and *j* are (0,1) which means the attribute does not exist in *i* but is in *j*, *c* is the number of attributes where the values of *i* and *j* are (1,0), which means the attribute exists in *i* but does not exist in *j* and *d* are the number of attributes owned by *i* and *j* (0,0), which means that the attribute does not exist in *i* and also does not exist in *j* [17].

Table 2: OTUs Expression of Binary Instances *i* and *j*

	1 (Presence)	0 (Absence)
1 (Presence)	$a = i . j$	$b = i \bar{.} j$
0 (Absence)	$c = i . j \bar{}$	$d = i \bar{.} j \bar{}$

Based on OTUs, then Dice Similarity can be written:

$$S_{Dice} = \frac{2a}{2a+b+c} \quad (7)$$

3.3. Case Representation

This research will design a system that contains advice on ingredients and Indonesian culinary recipes from a consultation on ingredients that are owned to get a recipe suggestion that is closest to the availability of ingredients. The working principle of this system is the user has the desire to make a dish. The dishes that will be made are adjusted to the ingredients that are owned by the user. From the availability of ingredients, it will be included as a consultation by the user to the system. Weight categories are divided into five groups of ingredients. Each group of ingredients is given a different weight value, with the aim of increasing the value of similarity between consultation and recipe suggestions, as shown in figure 1.

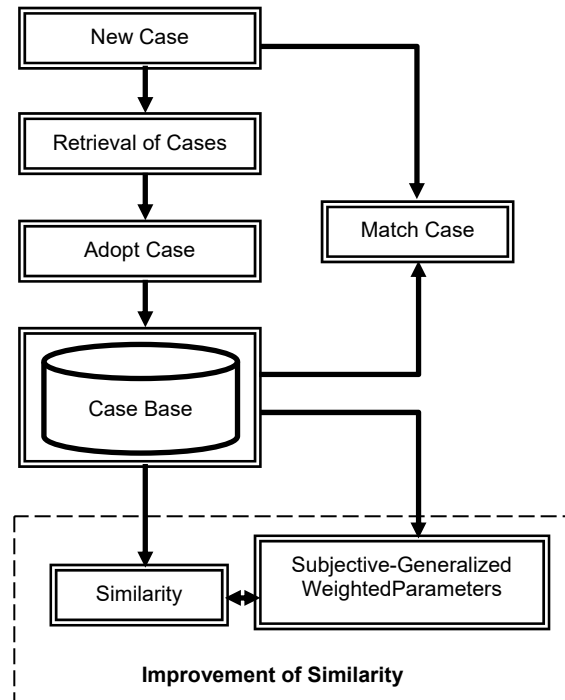

Figure 1: Proposed Model for Improvement of CBR

To determine the decision of the decision made by matching the input of food ingredients that are owned compared with the ingredients used in a recipe, where the recipe data has been stored previously in the database. The similarity between the ingredients entered with the ingredients in an existing food recipe is calculated using a similarity algorithm. CBR in this study to get the similarity of old cases in Indonesian cuisine recipes. The system will provide users with the highest level of recipe suggestions for cooking.

An attempt to improve the similarity value in a Dice similarity algorithm is done by adding weight to each parameter of the ingredients, where the weight is given subjectively while still considering the principle of general appropriateness. The method used to give weight is to classify ingredients based on the role of ingredients in providing differences in each dish. In this study the method of assigning weight values is called subjective generalized method. Technical weighting is to provide the highest weight for cooking ingredients which are the main ingredients of a dish. In the cooking ingredients which are the most widely used ingredients in almost all dishes will be given the lowest weight. Dice similarity algorithm will be used as a formula to calculate the similarity value based on weighting parameters (ingredients). The result of the similarity calculation will be in the

form of a similarity percentage ranging from 0% to a maximum of 100%. A value of 0% indicates that there are no recipes that are completely similar, while a value of 100% states there is a recipe that has exactly the same ingredients as the ingredient consulted.

An attempt to improve the similarity value in a Dice similarity algorithm in the Case Based Reasoning method is to give weight to each parameter in the subjective generalized weighting system for traditional Indonesian culinary recipes done with the following stages:

1. Designing weight values for each group of ingredients for each traditional Javanese culinary recipe. Weighting each parameter group uses weighting with reference to the AHP (Analytical Hierarchy Process) method.
2. Calculate the similarity value using the Dice similarity algorithm based on weighting the ingredients parameters of each Indonesian culinary recipe.
3. Provides a suggestion for recipes with the highest level of resemblance to the user

3.4. Subjective Generalized Weighted

Determination of the weight of a food ingredient as forming a food recipe, it is necessary to do a hierarchy arrangement. The arrangement of the hierarchy is done by determining the depiction and determining the pattern of the hierarchy. Bigger problems are broken down into smaller problems, with the principle of detailing knowledge and provisions that have become general rules into the basic elements forming general rules, then the main elements are broken down into smaller elements, and so on so that they can be described in hierarchical form.

The breakdown of the hierarchy at a more detailed level is carried out in order to determine measurable criteria. When the level of elaboration becomes lower to determine a goal, it is relatively easier to determine the size of the objectivity and decision-making criteria. If in a case the process of determining results does not require a more detailed description, then the method used is a statement of achievement measures using a subjective scale. The most important part of the analysis process is the following three stages:

1. Determination of the purpose of analysis: determine recipes.
2. Determination of the group criteria for ingredients: main ingredients, supporting ingredients, main seasonings, supporting herbs, general seasonings.

3. Determination of alternative choices: other dishes as an alternative choice besides the recommended dishes.

The information that has been obtained is then represented to determine the relative rank of the alternative choices that have been determined. Criteria of qualitative and quantitative types can be compared using known decisions to calculate weights and priorities. In determining the ranking of a group of criteria, the determination of weights can be done by the system maker by looking at recommendations based on decision-making rules that have become general rules but have not been quantitatively detailed.

The ingredients and spices forming traditional culinary recipes are grouped into 5 groups of parameters namely:

1. The main ingredients group, grouped in the category of extreme importance. The main ingredients are ingredients that have the most important role and become the highest differentiating factor in a dish. The weight value of a food ingredient will be given the highest if the food ingredient is the main ingredient in forming the recipe. Usually in Indonesia this ingredient is a food ingredient that is classified as protein, both animal and vegetable. This ingredient is in a dish as the main ingredient that makes the difference between recipes, thus the weight value given is the highest.
2. Supporting material groups or secondary, grouped in the category of very strong. Supporting materials are supporting materials for the main ingredients in forming recipes. In Indonesia, this material is usually in the form of vegetables. Thus the weight value given is quite high.
3. The main spice group, grouped in the category of Strong importance. The main seasoning is seasoning which has the most important role in giving flavor in the recipes. The main seasoning is forming the taste at the main level for a recipe. Thus, the weight value given is moderate.
4. Supporting spice groups, grouped in the category of moderate importance. Supporting spice is a spice that functions in supporting the taste of a recipe. Supporting spices are present in most recipes, but not all recipes use them. Therefore, the weight value is low.
5. Common spices group, grouped in the category of equal importance. Common spices are seasonings that are generally found in most dishes, for example: water, salt, sugar and

others. This general spice has the least role in differentiating one recipe from another, so the ingredients are grouped into very common ingredients, so the weight value is the lowest.

3.5. Weight Validity Test

In applying the validity test to the weight of cooking ingredients using a pairwise comparison table, the steps to determine whether the weights determined earlier are included in the valid assessment or not, then the steps taken are:

1. Determination of the relative importance of the components of a dish is done by making a subjective determination, but taking into account the general limitations of practitioners/experts in the culinary field. In CBR with weighting for each attribute, subjective weighting is determined as follows:
 1. Main Ingredients 9 times more important than General Seasoning
 2. Main Ingredients 7 times more important than Supporting Spices
 3. Main Ingredients are 5 times more important than Main Seasoning
 4. Main Ingredients are 3 times more important than Support Materials
 5. Supporting Materials 7 times more important than General Seasoning

6. Supporting Materials are 5 times more important than Supporting Spices
 7. Supporting Materials 3 times more important than the Main Seasoning
 8. Main Seasoning is 7 times more important than General Seasoning
 9. The Main Seasoning is 3 times more important than the Supporting Seasoning
 10. Supporting Spices 5 times more important than General Spices
2. The design of a comparison table using pairwise comparison, the level of importance of one attribute compared to other attributes can be expressed in the form of values with criteria:
 1. A value of 1 is defined as: equal
 2. Value 3 is defined as: moderate
 3. Value 5 is defined as: strong
 4. A value of 7 is defined as: very strong
 5. The value 9 is defined as: extreme
 3. Based on the determination of the attribute values above, a pairwise comparison table is made as shown in table 3. Weighting each group of parameters uses weighting in the AHP method. This method requires a CR ratio of equal or less than 10 percent.

Table 3: Pairwise Comparison of Parameters

	P1	P2	P3	P4	P5
P1	1	3	5	7	9
P2	0.333333	1	3	5	7
P3	0.2	0.333333	1	3	7
P4	0.142857	0.2	0.333333	1	5
P5	0.111111	0.142857	0.142857	0.2	1
	$\Sigma = 1.78730$	$\Sigma = 4.67619$	$\Sigma = 9.47619$	$\Sigma = 16.2$	$\Sigma = 29$

- P1 = representation of the Main Ingredients
- P2 = representation of the Supporting Materials
- P3 = representation of the Main Seasoning
- P4 = representation of the Supporting Spices
- P5 = representation of the General Seasoning

2. The process of multiplying the number of each parameter with each weight can be seen in table 4.

Table 4: Multiplication of Quantities and Weights

	P1	P2	P3	P4	P5
amount (Σ)	1.787301587	4.67619	9.47619	16.2	29
amount * weight	0.901912279	1.220635	1.29939	1.129669	0.797253393

3. The calculation results of λ max can be calculated using equation (1) the results are obtained:
 $\lambda_{max} = 5.34885990096474$
4. Calculating the CI (Consistency Index) can be calculated using equation (2) the results are obtained:
 $CI = 0.087214975$

5. Calculating CR (Consistency Ratio) can be calculated using equation (3), the following results are obtained:
 $CR = 0.077870514$
6. Consistency Ratio shows the result of 0.077870514, where CR is said to be valid if it is less than 0.1, then in this process CR is declared valid. The results of weighting each parameter produce:
7. Each cooking ingredient is weighted as shown in table 5.
- P1 = 0.504622323
 P2 = 0.261031973
 P3 = 0.137121547
 P4 = 0.069732661
 P5 = 0.027491496

Table 5: Material, Category and Weight

ID	Ingredients	Category	Weight of Ingredients
B001	Water	General Seasoning	0.027491496
B002	Tamarind	General Seasoning	0.027491496
B003	Chicken	Main Ingredients	0.504622323
B004	Gizzard Heart	Main Ingredients	0.504622323
B005	Onion	Supporting Spices	0.069732661
B006	Shallot	Supporting Spices	0.069732661
B007	Garlic	Supporting Spices	0.069732661
B008	Spinach	Supporting Materials	0.261031973
B009	Vermicelli	Supporting Materials	0.261031973
B010	Bean	Supporting Materials	0.261031973
B011	Green Chili	Supporting Spices	0.069732661
B012	Red Chili	Supporting Spices	0.069732661
B013	Cayenne Pepper	Supporting Spices	0.069732661
B014	Caisim	Supporting Materials	0.261031973
B015	Clove	Main Seasoning	0.137121547
B016	Vinegar	Main Seasoning	0.137121547
B017	Lamb	Main Ingredients	0.504622323
B018	Beef	Main Ingredients	0.504622323
B019	Leek	Supporting Materials	0.261031973
B020	Lime Leaves	Supporting Spices	0.069732661
B021	Papaya Leaf	Supporting Materials	0.261031973
B022	Banana Leaf	Supporting Materials	0.261031973
B023	Bay Leaf	Supporting Spices	0.069732661
B024	Melinjo Leaf	Supporting Materials	0.261031973
B025	Sweet Potato Leaves	Supporting Materials	0.261031973
B026	Dry Shrimp	Supporting Materials	0.261031973
B027	Salt	General Seasoning	0.027491496
B028	Palm Sugar	Main Seasoning	0.137121547
B029	Sugar	General Seasoning	0.027491496
B030	Roomie Sugar	General Seasoning	0.027491496
B031	Chicken's Liver	Main Ingredients	0.504622323
B032	Beef Liver	Main Ingredients	0.504622323
B033	Goat Ribs	Main Ingredients	0.504622323
B034	Smoked Fish	Main Ingredients	0.504622323
B035	Peda Salted Fish	Main Ingredients	0.504622323
B036	Snapper	Main Ingredients	0.504622323
B037	Mackarel Tuna	Main Ingredients	0.504622323
B038	Corn	Supporting Materials	0.261031973
B039	Ginger	Main Seasoning	0.137121547
B040	Jengkol	Supporting Materials	0.261031973
B041	Lemon	Supporting Spices	0.069732661
B042	Lime	Supporting Spices	0.069732661
B043	Cumin	Main Seasoning	0.137121547
B044	Long Beans	Supporting Materials	0.261031973

B045	Red Beans	Supporting Materials	0.261031973
B046	Peanuts	Supporting Materials	0.261031973
B047	Broth	Supporting Materials	0.261031973
B048	Kale	Supporting Materials	0.261031973
B049	Cinnamon	Main Seasoning	0.137121547
B050	Soy Sauce	Supporting Spices	0.069732661
B051	Coconut	Supporting Spices	0.069732661
B052	Mongoose	Main Seasoning	0.137121547
B053	Basil	Supporting Materials	0.261031973
B054	Candlenut	Main Seasoning	0.137121547
B055	Galangal	Main Seasoning	0.137121547
B056	Potato	Supporting Materials	0.261031973
B057	Clam	Main Ingredients	0.504622323
B058	Coriander	Main Seasoning	0.137121547
B059	The Diamond	Supporting Materials	0.261031973
B060	Cabbage	Supporting Materials	0.261031973
B061	Cheeky	Main Ingredients	0.504622323
B062	Turmeric	Main Seasoning	0.137121547
B063	Chayote	Supporting Materials	0.261031973
B064	Galangal	Main Seasoning	0.137121547
B065	Beef Tongue	Main Ingredients	0.504622323
B066	Maize	Supporting Materials	0.261031973
B067	Butter	Supporting Materials	0.261031973
B068	Pepper	Main Seasoning	0.137121547
B069	Yellow Noodles	Supporting Materials	0.261031973
B070	Noodles Stick	Supporting Materials	0.261031973
B071	Vegetable Oil	Supporting Spices	0.069732661
B072	Young Jackfruit	Supporting Materials	0.261031973
B073	Nutmeg	Main Seasoning	0.137121547
B074	Bitter Melon	Supporting Materials	0.261031973
B075	Petai	Supporting Materials	0.261031973
B076	Chinese Cabbage	Supporting Materials	0.261031973
B077	Celery	Supporting Materials	0.261031973
B078	Lemongrass	Main Seasoning	0.137121547
B079	Glass Noodles	Supporting Materials	0.261031973
B080	Tofu	Main Ingredients	0.504622323
B081	Bean Sprouts	Supporting Materials	0.261031973
B082	Egg	Main Ingredients	0.504622323
B083	Tempeh	Main Ingredients	0.504622323
B084	Rotten Tempeh	Main Ingredients	0.504622323
B085	Rice Flour	Supporting Materials	0.261031973
B086	Sago Flour	Supporting Materials	0.261031973
B087	Wheat Flour	Supporting Materials	0.261031973
B088	Shrimp Paste	Main Seasoning	0.137121547
B089	Anchovy	Main Ingredients	0.504622323
B090	Eggplant	Supporting Materials	0.261031973
B091	Cucumber	Supporting Materials	0.261031973
B092	Tomato	Supporting Materials	0.261031973
B093	Shrimp	Main Ingredients	0.504622323
B094	Carrot	Supporting Materials	0.261031973

4. CASE STUDY

4.1. Analyze

The weighting design and implementation of the Dice similarity algorithm that has been made will be tested to determine the performance of the

development of the algorithm, and the following test results in some cases. Case calculation with ID_Case: K001 compared to recipe with ID_Reception: M037, with recipe name: Inkgung.

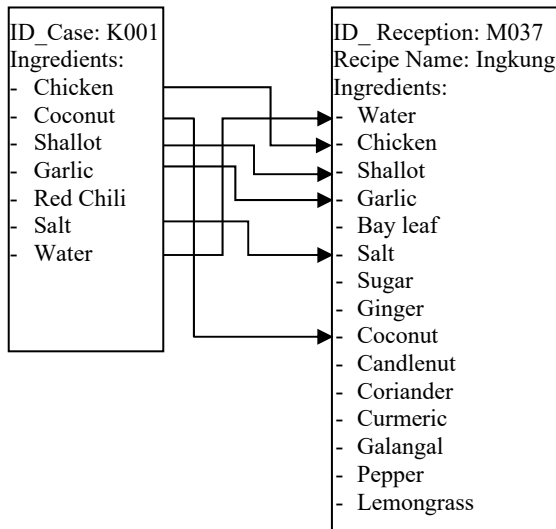

Figure 2: Matching Consultations and Recipes

In this process the system does the matching of ingredients that are owned and then matched with the ingredients forming the recipe for all the recipes in the database. There will be known three important things, namely:

1. Ingredients that are both owned by the new case consulted and the recipe stored in the database, which if represented in the formula for calculating Dice similarity is symbolized by 'a'. The ingredients included in 'a' are chicken, coconut, onion, garlic, salt, water.
2. Food ingredients that are not owned by the new case, but are owned by recipes in existing databases which if represented in the calculation formula Dice similarity is symbolized by 'b'. The ingredients included in 'b' are bay leaves, sugar, ginger, candlenut, coriander, turmeric, galangal, pepper, lemongrass.
3. Food ingredients that are owned by a new case, but are not owned by recipes that exist in the database which if represented in the formula for calculating Dice similarity are symbolized by 'c'. The ingredients included in the 'c' are red chillies.

The following is an example of the process of calculating the similarity value using the Dice algorithm without the weighting value on each cooking ingredient, compared to one of the recipes:

- ID_Recipe: M037
- The name of the recipe: Ingkung
- The process of calculating the similarity value by weighting using the Dice algorithm, by first looking for the values of a, b and c, the following results are obtained:

$$a = 6$$

$$b = 9$$

$$c = 1$$

- The similarity value using the Dice algorithm can be calculated using equation (7) to obtain the results:

$$S_{Dice} = \frac{2a}{2a + b + c}$$

$$S_{Dice} = \frac{2 \times 6}{(2 \times 6) + 9 + 1}$$

$$SDice = 0.5454545$$

- It is known that in the case with ID_Case: K001 compared to cooking recipes: M037 a similarity value of 0.504 will be obtained, which can be interpreted that the K001 case has a relatively moderate similarity, because it is in the middle of a similarity value where the similarity value has a range of 0 to 1. The value of 0 is a value that states there is no resemblance at all, while the value of similarity 1 is a value that states that the new case is exactly the same as the recipe in the database. With the same consultation example, the similarity value calculation process will be carried out using the Dice algorithm accompanied by a weighting value on each cooking ingredient, compared to one of the same cooking recipes as well:

- ID_Recipe: M037
 - The name of the recipe: Ingkung
 - The process of calculating the similarity value by weighting using the Dice algorithm, by first looking for the values of a, b and c, the following results are obtained:
- $$a = 0.504622323 + 0.0697327 + 0.0697327 + 0.0697327 + 0.027491496 + 0.027491496$$
- $$a = 0.768803415$$
- $$b = 0.0697327$$
- $$c = 0.0697327 + 0.027491496 + 0.1371215 + 0.1371215 + 0.1371215 + 0.1371215 + 0.1371215 + 0.1371215$$
- $$c = 1.057074696$$

- The similarity value using the Dice algorithm can be calculated using equation (7) to obtain the results:

$$S_{Dice} = \frac{2a}{2a + b + c}$$

$$S_{Dice} = \frac{2 \times 0.768803}{(2 \times 0.768803) + 0.069732 + 1.057074}$$

$$S_{Dice} = 0.577090009126832$$

- It is known that in the case with ID_Case: K001 compared to the recipe: M037 a similarity value of 0.577090009126832 can be

obtained, which means that the case of K001 has a relatively moderate similarity.

Table 6 shows a consultation with the same ingredients as the two previous experiments. In this experiment, the main ingredient used is chicken, so expect similarity values for recipes using chicken as

the main ingredient will obtain high similarities. Here it is shown that in general the value of similarity when using a weighted Dice is lower when compared to an unweighted Dice.

Table 6: Comparison of The Value of Weighted Dice Similarity and Unweighted Dice Similarity

MATERIALS CONSULTATION	NO	NAME OF CUISINE	SIMILARITY VALUE	
			WEIGHTED DICE	UNWEIGHTED DICE
1. Chicken	1	Rendang Jengkol	0.314800066	0.6
2. Coconut	2	Pepes Ikan	0.159666935	0.444444
3. Shallots	3	Sambel Tempe	0.157869619	0.4
4. Garlic	4	Mangut	0.166742362	0.5
5. Red Chili	5	Orak Arik Pedho	0.135602114	0.333333
6. Salt	6	Tumis Daun Pepaya	0.21087596	0.47619
7. Water	7	Oseng Pare	0.288095987	0.588235
	8	Lodeh	0.209256453	0.545455
	9	Selat Solo	0.088160348	0.3
	10	Garang Asem	0.61055378	0.7
	11	Acar Tahu	0.107312153	0.380952
	12	Ayam Bakar	0.536510475	0.375
	13	Sate Kere	0.116973037	0.333333
	14	Plecung Kangkung	0.123989897	0.285714
	15	Sambel Tumpang	0.13375938	0.428571
	16	Soto Sapi	0.129259338	0.380952
	17	Tengkleng Ayam	0.510708257	0.461538
	18	Sambel Terasi	0.198730535	0.4
	19	Brambang Asem	0.203855474	0.4
	20	Asem Asem	0.182306523	0.47619
	21	Timlo Solo	0.38067612	0.4
	22	Kare Ayam	0.408387939	0.461538
	23	Urap	0.297746594	0.5
	24	Tempe Bacem	0.222932282	0.571429
	25	Terik	0.210161021	0.5
	26	Tengkleng	0.091360741	0.315789
	27	Tongseng Sapi	0.149559072	0.357143
	28	Kupat Tahu	0.069835759	0.285714
	29	Sambel Goreng Kentang	0.239446511	0.6
	30	Sate Kambing	0.094957802	0.266667
	31	Sate Buntel	0.148258173	0.375
	32	Tongseng Kambing	0.164197094	0.416667
	33	Tahu Aci	0.079114009	0.25
	34	Soto Kudus	0.372881508	0.424242
	35	Sambel Goreng Ati	0.218402383	0.6
	36	Krengsengan	0.163525728	0.4
	37	Ingkung	0.577089918	0.545455
	38	Trancam	0.147024028	0.347826
	39	Mendoan	0.101581474	0.4
	40	Opor	0.592064529	0.545455

Using the results in table 6, table 7 can be made which contains the ten highest values of similarity when using the weighted Dice algorithm and unweighted Dice. When using the weighted Dice similarity algorithm, then of the ten highest ranks there are eight recipes with the main

ingredient in the form of chicken, but when using the unweighted Dice algorithm, of the ten highest ranks there are only three recipes with the main ingredient in the form of chicken. In the weighted Dice algorithm, recipes using chicken as the main ingredient are ranked one through eighth, while in

the unweighted Dice algorithm, recipes using and nine. chicken as the main ingredient are ranked one, eight

Table 7: Comparison of The Ten Highest Value of Similarity Weighted Dice and Unweighted Dice

NO	WEIGHTED DICE		UNWEIGHTED DICE	
	NAME OF CUISINE	SIMILARITY VALUE	NAME OF CUISINE	SIMILARITY VALUE
1	Garang Asem	0.61055378	Garang Asem	0.7
2	Opor	0.592064529	Rendang Jengkol	0.6
3	Inkung	0.577089918	Sambel Goreng Kentang	0.6
4	Ayam Bakar	0.536510475	Sambel Goreng Ati	0.6
5	Tengkleng Ayam	0.510708257	Oseng Pare	0.588235
6	Kare Ayam	0.408387939	Tempe Bacem	0.571429
7	Timlo Solo	0.38067612	Lodeh	0.545455
8	Soto Kudus	0.372881508	Inkung	0.545455
9	Rendang Jengkol	0.314800066	Opor	0.545455
10	Urap	0.297746594	Mangut	0.5

4.2. Comparative Results

In this experiment, we used 40 recipes, while the ingredients for the consultation were: Chicken as main ingredients

1. Coconut as supporting spices
2. Shallots as supporting spices
3. Garlic as supporting spices
4. Red Chili as supporting spices
5. Salt as general seasoning
6. Water as general seasoning

In the case where chicken is used as the main ingredient of consultation, the weighted Dice similarity value results in four recipes with chicken main ingredients whose value is higher than the similarity of the weightless Dice, as shown in Figure 3.

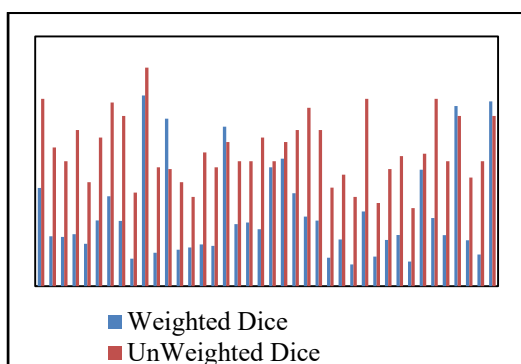

Figure 3: Comparison of Similarity Value

Chicken as the main ingredient is given the highest weight. Giving the highest weight for the main ingredient is used in determining the purpose of using case based reasoning to be achieved, namely the compatibility between the ingredients of the food consulted with the recipe suggested [18].

In this experiment there was only 10% higher weighted Dice similarity value than the unweighted Dice similarity value. The four recipes are Ayam Bakar, Tengkleng Ayam, Opor and Inkung, but it should be noted that the main ingredients forming all these recipes are chicken. If the factor considered is the accuracy of the resulting recipes compared with the main ingredient in the consultation input, then it can be said that chicken as the main ingredient of the consultation will produce recipes with the main ingredient of chicken as well. This can be said to be a fairly relevant result. When related to the basic principle of CBR, the main assumption in this study is to place a large weight on the main ingredient to get recipe recommendations similar to the main ingredient, here the hypothesis is used that the same problem must have a similar solution [19].

This is reinforced by the results in table 7, which takes the data of the ten highest values of weighted Dice, stating that with the main ingredients the chicken gets 80% of recipes made from chicken as well. The highest similarity value in weighted Dice is ranked first up to eighth. On the other hand, if based on the value of unweighted Dice, consultations that use the main ingredients of chicken only get 30% of recipes with chicken main ingredients as well. The highest similarity value in weighted Dice is first, eighth and ninth. This means that if the accuracy factor is considered, if using unweighted Dice, the similarity value is considered not relevant enough.

5. CONCLUSION

Providing recommendations for a recipe consultation based on available food ingredients, the weighting can be done subjectively but must

still consider the generalized principle. The value of a given weight can be tested for validity using the principles of weighting in AHP. About what is new in this research is combining the Dice similarity value calculation method with the generalized subjective weighting method and a valid objective weighting method, so that the combination of subjectivity rating given by the expert and objectivity of the data is obtained. This makes the results obtained, in this case the recipe recommendations become more accurate by considering more the main ingredients forming the recipe.

REFERENCES

- [1] Wibisono, S. & Utomo, M.S. (2016). Dynamic Stoplist Generator From Traditional Indonesian Cuisine With Statistical Approach, *Journal of Theoretical and Applied Information Technology*, Vol.87, No.1, 2016, pp.92-98.
- [2] Aamodt, A., & Plaza, E. (1994). Case-based reasoning: Foundational issues, methodological variations, and system approaches. *AI communications*, 7(1), 39-59.
- [3] Li, H., Adeli, H., Sun, J., & Han, J. G. (2011). Hybridizing principles of TOPSIS with case-based reasoning for business failure prediction. *Computers & Operations Research*, 38(2), 409-419.
- [4] Chattopadhyay, S., Banerjee, S., Rabhi, F. A., & Acharya, U. R. (2013). A Case-Based Reasoning system for complex medical diagnosis. *Expert Systems*, 30(1), 12-20. Lu, L., & Li, B. (2014). Combining Different Feature Weighting Methods for Case Based Reasoning.
- [5] Leake, D. B. (1996). *Case-Based Reasoning: Experiences, lessons and future directions*. MIT press.
- [6] Ahn, H., Kim, K. J., & Han, I. (2004). Simultaneous optimization of feature weighting and instance selection in case-based reasoning systems using genetic algorithms. In *9th Asia-Pacific DSI Conference*.
- [7] Jiyin, C., Shidong, F., Wen, L., & Haiyun, L. (2014). Information Support Technology of Ship Survey Based on Case-based Reasoning. *Telkomnika*, 12(4), 985.
- [8] Suwarningsih, W., Supriana, I., & Purwanti, A. (2015, August). Indonesian medical retrieval case based on knowledge association rule similarity. In *2015 International Conference on Control, Electronics, Renewable Energy and Communications (ICCEREC)* (pp. 142-147). IEEE.
- [9] Giri, G. A. V. M., & Harjoko, A. (2016). Music Recommendation System Based on Context Using Case-Based Reasoning and Self Organizing Map. *Indonesian Journal of Electrical Engineering and Computer Science*, 4(2), 459-464.
- [10] Gatzidou, A., & Sánchez-Marrè, M. (2017, April). A case-based reasoning framework for music playlist recommendations. In *2017 4th International Conference on Control, Decision and Information Technologies (CoDIT)* (pp. 0242-0247). IEEE.
- [11] Purwandari, E. P., Yani, A. P., Sugraha, R., Anggriani, K., & Winarni, E. W. (2017). Online Expert Systems for Bamboo Identification Using Case Based Reasoning. *International Journal of Electrical & Computer Engineering* (2088-8708), 7(5).
- [12] Hadikurniawati, W., & Wardoyo, R. (2015). A Hybrid Multi-Attribute Decision Making for Electrician Selection Based on AHP, SAW and TOPSIS. *Journal of Theoretical & Applied Information Technology*, 77(1).
- [13] Mu, E., & Pereyra-Rojas, M. (2017). Practical Decision Making. SpringerBriefs in Operation Research, Vol. 2.
- [14] Saaty, T. L. (2008). Decision making with the analytic hierarchy process. *International journal of services sciences*, 1(1), 83-98.
- [15] Guo, G., Wang, H., Bell, D., Bi, Y., & Greer, K. (2003, November). KNN model-based approach in classification. In *OTM Confederated International Conferences" On the Move to Meaningful Internet Systems"* (pp. 986-996). Springer, Berlin, Heidelberg.
- [16] Dice, L. R. (1945). Measures of the amount of ecologic association between species. *Ecology*, 26(3), 297-302.
- [17] Everitt, D. G., & Dunn, G. (1982). An introduction to mathematical taxonomy. *Cambridge: Cambridge University*.
- [18] Zhang, Z. (1997). *Static and dynamic feature weighting in case-based reasoning (CBR)* (Doctoral dissertation, Theses (School of Computing Science)/Simon Fraser University).
- [19] Núñez, H., Sanchez-Marre, M., Cortés, U., Comas, J., Martínez, M., Rodríguez-Roda, I., & Poch, M. (2004). A comparative study on the use of similarity measures in case-based reasoning to improve the classification of environmental system situations. *Environmental Modelling & Software*, 19(9), 809-819.