

PID IMPLEMENTATION ON REAL TIME 3-PHASE INDUCTION MOTOR CONTROLLING AND MONITORING

¹ANSAR SUYUTI, ²INDAR CHAERAH GUNADIN., ³NURHAYATI

^{1,2,3}Department of Electrical Engineering, Hasanuddin University, Indonesia

E-mail: ¹asuyuti06@yahoo.com, ²indarcg@gmail.com, ³nurhayati900716@gmail.com

ABSTRACT

This research aims to compare and determine the real time influences of tuning PID on the 3-phase induction motor real time using INFOU SCADA and monitor the alterations of frequency, current, voltage and power as well using PQM II. Tuning PID determination based on trial and error method then the curve were displayed on INFOU SCADA and motor data were showed from PQM II. The results of this research are the great influences of PID controller on induction motor. The composite of controlling P, I, and D is able to improve the time rise and offset level. By setting the value of SV on 1500 rpm and PID value, such as $P = 1$, $I = 10$, and $D = 0$, the motor response displayed on INFOU SCADA graphic was good where time for PV to get SV was fast enough 11 seconds. While motor data monitored on PQM panel showed optimum speed of motor and did not exceed motor capacity that is on its name plate. Frequency, current, voltage and active power were 50 Hz, 1 Ampere, 151 Volt, and 0.06 kW respectively. The effect of tuning PID on speed of 3-phase induction motor is seen on the graphic that are showed on INFOU SCADA while the other variables are seen on the INFOU SCADA and PQM II panel connected with 3-phase induction motor.

Keywords: 3-Phase Induction Motor, PID, PQM II

1. INTRODUCTION

Production system in the industrial sector is an important issue and often becomes complex because of unintended conditions. Those conditions are caused by the bad readability of control system on production proses. In order to obtain the desired results, while producing, the readability of equipment must be kept.

In the operation of an electric motor, the motor speed respon is definitely desired to be constant even if load changes. This problem can be overcome by using a system controller proportional, integrative, and derivative (PID) which can be created on the ladder diagram KGL_WIN. It provides PID controller. The relationship between the process of controlling three-phase induction motor and the PID algorithm controller can use the system supervisory control and data acquisition (SCADA). SCADA has some fiturs like cimon, intellution fix 6.1, info_u and so on. The program used to control the three-phase induction motor is SCADA info_u. It is chosen because it easly read the motor respons. Moreover it does not need the ladder diagram.

The influences of PID controller to the three-phase induction motors, such as current, voltage, and power can be seen in the PQM II panel or the SCADA infou display. Then it simplifies the process of collecting data. Based on this reason, research about the influences of PID controller is important to be done.

Some problems that will be discussed in this paper are how to control three-phase induction motor using PID, how to determine the effect of PID on the three-phase induction motor, and how to display implementation of the PID controller on the three-phase induction motor speed.

Some studies about the implementaion of PID have done before. One of those is The Intelligent self tuning PID controller using hybrid improved particle swarm optimization for ultrasonic motor (USM). This research was done because of the complexity of the mathematical models and the characteristic changes of ultra sonic motors during operation. By using Hybrid Particle Swarm Optimization (PSO), the accuration of position and speed convergence USM can be determined.

The next research was the implementation of PID to control the temperature of baby incubator has been done. The aim of this study was to carry



babies who are prematurely born so they can survive and adapt to the outside temperature [2].

By using fuzzy algorithm in MATLAB simulation PI was also applied in order to control The switched reluctance motor (SRM). The conclusion of this research was that the fuzzy PI algorithm was reliable in a wide range of torque load profile and protecting the motor from overcurrent and overload [3].

The other research was about PID controller implementing Genetic Algorithm for voltage stability on synchronous machine. This method applies GA as the scale of input and output factor, error change, and action control from fuzzy PID controller. The result of this application is compared with the synchronous generator that was not controlled. Integral Square Error (ISE %) is used to determined the respons of synchronous machine. This research resulted in the efectivity of GFPID controller that is able to control the respon of voltage terminals, increasing respons, and decreasing the steady-state error, rise time, and settling time as well. Type GFPID-2 with the gave the best transient respon compared with other types of controllers. Furthermore, ISE has stricly alleviated from 27.4 without controller until 1.076 with new controller or ISE % greatly cut down from 96,05%. The ZN tuning method clearly prove that it has the obviously short settling time of relative controller.[4]

A Fuzzy Gain Porportional Integrative (FGPI) controller is used for controlling the output voltage of an AC/DC converter. In the proposed system, the converter is composed of isolated CUK power factor correction circuits those parallel-connected for increasing power capacity. For the flexibility and modularity purpose, each converter module employs an individual microcontroller to control the power converter operation and communicate among other converter modules for load current sharing. The microcontroller in each module communicates to each other via RS485 serial communication bus. To avoid the data collision on the communication bus, a synchronization signal is used to synchronize the time slot of microcontrollers in the system for sending and receiving data. The FGPI controller is used to improve dynamic response of the output voltage loop while an analog hysteresis current controller is used to control the input current of each converter. Three-250 W/module AC/DC converters are designed and built to verify the operation of the proposed system. The experimental results show that the proposed system provides fast response of the output voltage control, and that current sharing

of each module is quite good and that a high input power factor is achieved [5].

This research is different with the previous researches. It used trial and error method by comparing between its graphic for every sampling on SCADA Infou and the results of monitoring displayed on PQM II in order to get PID values that are suitable with the optimum speed of 3-phase induction motor. There are some advantages of this study. First of all, we can directy define the implementation of PID controller on motor. Second, it can monitor every alteration of motor speed, voltage, current, daya, and frequency as well. Third, we are definitely able to determine the range of each controller value (kp, ki, and kd) that affec time rise, settling time, oscilation, and overshoot on the 3-phase induction motor. And the last one, by using SCADA expected data on the 3-phase induction motor can easily know and display them on the graphics.

2. FUNDAMENTAL THEORY

2.1 Three-phase induction motor

An induction motor is an electrical machine that converts electrical energy into mechanical energy. The principals of three-phase induction motor operation: when the 3-phase AC power is supplied to the motor's stator, magnetic field rotates with synchronous speed, $n_s = 120 f / p$. Where n_s is synchronous speed (meter/second (m/s)), f is frequency (hertz (Hz)), and p is the number of magnetic poles. The rotating magnetic field passes through the rotor conductor. So on the rotor electromotive force (emf) will be created with equation $e = 4,44 f n \phi$. Where e is electromotive force (joule/coulomb(j/c)), f is frequency (Hz), n is number or windings, and ϕ is flux (Wb). Since rotor winding is close loop, it results in current (i). The current inside of magnetic field creates force (f) on the rotor [6].

2.2 PID Controller

PID is a controller that can correct error in order to provide stabile output. The PID system keep objects (output) standing on set value (SV) and the value on the detected object is known as present value (PV). PID controls both of them in the same value. Then the difference between SV and PV is named deviation E. Subsequently, it will give manipulate value (MV) to actuator in order to force the object going back to set value (SV). PID components consist of Proportional, Integrative, and Derivative [7].

$$E = SV - PV \dots \dots \dots (1)$$

where :

E = Deviasi

SV = Set Value

PV = Present Value

$$MV(t) = Pout + Iout + Dout \dots\dots\dots (2)$$

Dimana :

P Kp = proporsional constantan

$$I Ki = integrative constantan = \int = \frac{1}{Ti s} = Ki/s$$

$$D Kd = derivative constantan = Td \frac{d e(t)}{dt}$$

Or the general equation :

$$Kp + \frac{1}{Ti} \int e(t) dt + Td \frac{d e(t)}{dt} = Kp [e(t) + \frac{1}{Ti} \int_0^t e(t) dt + Td \frac{d e(t)}{dt}] \dots\dots\dots (3)$$

2.2.1 Characteristics of PID Controller

Before the characteristics of PID controller are further explained, forms of output response that becomes targeted changes must be well known. They are showed on the picture below :

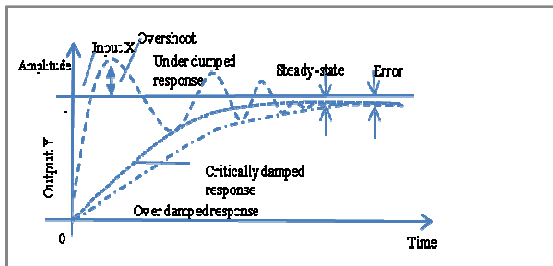

Figure 1:Kinds of Output Responses

Table 1: Characteristics of PID controller

CL Response	Rise Time	Over Shoot	Settling Time	S-S Error
Kp	Decrease	Increase	Small Change	Decrease
Ki	Decrease	Increase	Increase	Eliminate
Kd	Small Change	Decrease	Decrease	Small Change

2.3 Power Quality Meter

PQM (Power Quality Meter) is a tool that functions to determine the quality of the motor power. it needs a PLC (Programmable Logic Control) for controlling the system.

2.4 Infou SCADA

SCADA (Supervisory Control and Data Acquisition) is a system that gathers information or

data from field and afterward sends them to a center computer that manages and controls those data.

SCADA Infou has some advantages. Firstly it provides stabile and effective interface communication and component of graphic X active object. It enables users to design a graphic. Second, Action trigger and VB script are reliable and

ALTERNATING Type:
CURRENT SE2662-5K
Volts : 380 V KG : 19 H.P : 1.1
Hz: 50 A : 3/2.4 RPM:
2820/1400

flexible. And the last, it provides more than 1000 symbols on its library [8] .

3. METHODOLOGY

Some items that were analized in this research were the analysis of ladder diagram on KGL WIN and the analysis of PID design and implementation for 3-phase induction motor on SCADA Infou.

3.1 Diagram Blok

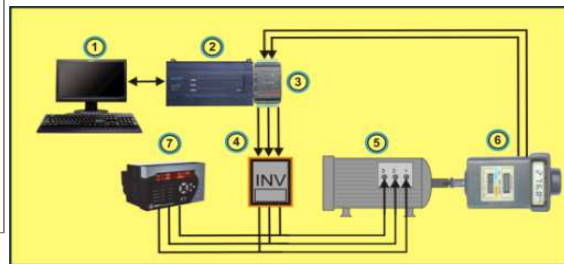

Figure 2 : Blok Diagram of controlling the speed of 3-phase induction motor using PID

Diagram Blok above includes of

1. Computer / Notebook
2. PLC LG
3. Analog I/O
4. Inverter
5. 3-phase induction motor
6. Tachogenerator
7. Power Quality Meter



Figure 3: Controlling And Monitoring 3-Phase Induction Motor

3.1 Flow Chart

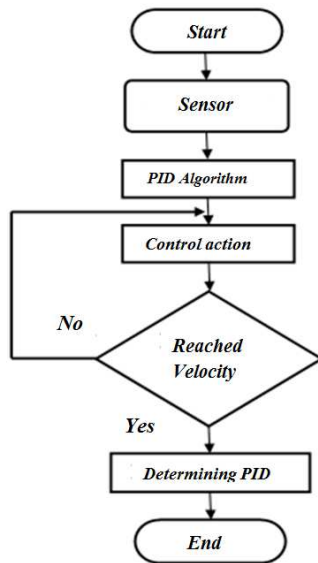

Figure 4: flow chart of controlling system

3.2 Open Loop Test

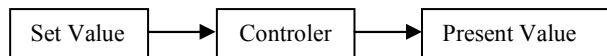

Figure 5: System Control Open Loop

3.2 Close Loop Test

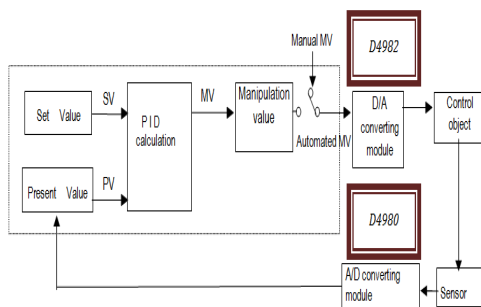

Figure 6: System Control Close Loop

4. ANALYSIS

The specifications of 3-phase induction motor used on this research :

4.1 Open Loop Test

The results of controlling and monitoring the three-phase induction motor are pointed out in the table 2.

Table 2. Data of the 3-phase induction motor frequency, voltage, current, and active power

t (s)	I (A)	V (V)	P (kW)
3	1	143	0.04

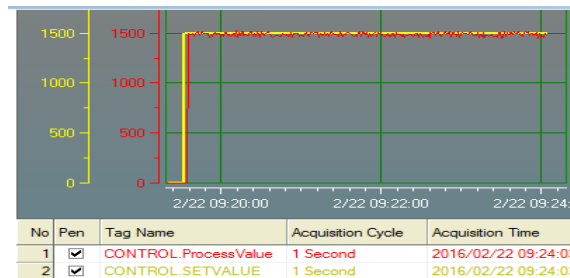

Figure 7: Graphic of Open Loop Test

On the open loop test, the motor speed with set value (SV) 1500 rpm and frequency 50 Hz can be quickly reached by the present value (PV). The response displayed on the INFOU SCADA showed unstable graphic, oscillation, and irregular refraction.

4.2 Close Loop Test

This research used tuning PID where $K_P = K_I$, $K_P > K_I$, $K_P < K_I$, union of K_P , K_I , and K_D . The data of monitoring 3-phase induction motor that was got from PQM II can be seen in table 3

Table 3. Monitoring Frequency, Voltage, Current and active Power Motor Induksi 3 Fasa Pada $K_P =$

PID	F (Hz)	T (s)	V (V)	I (A)	P (kW)
$K_P K_I = 1$	50	6	147	1	0.06
$K_P K_I = 10$	50	17	150	1	0.06
$K_P K_I = 100$	50	7	143	1	0.05

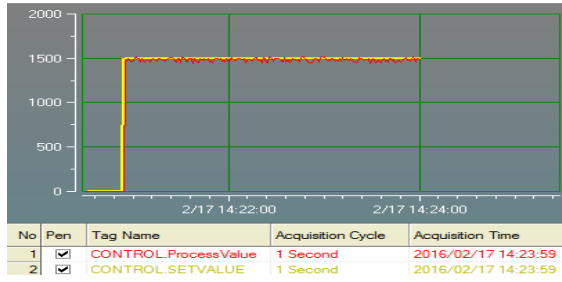

Figure 8. Graphic $KP = KI = 1$

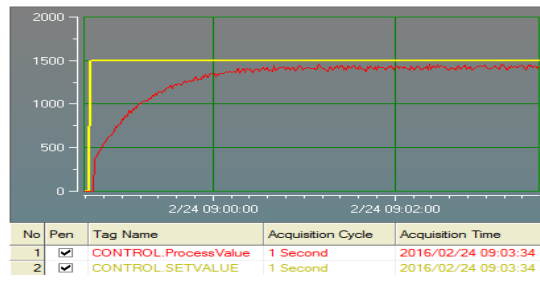

Figure 12. Graphic $KP=10$ $KI=100$

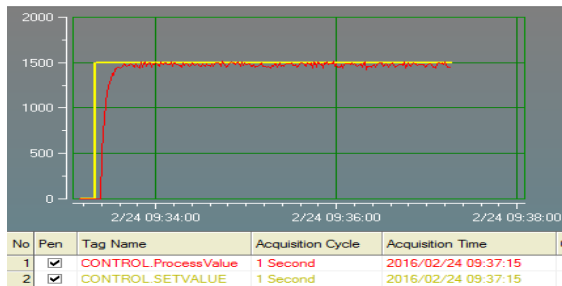

Figure 9. Graphic $KP = KI = 10$

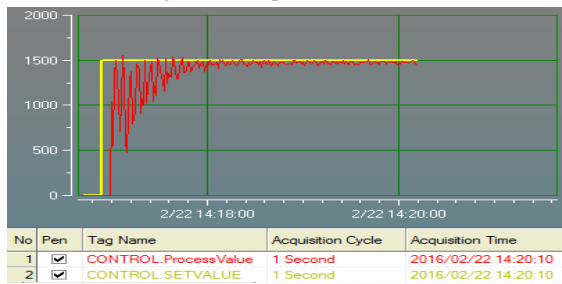

Figure 10. Graphic $KP = KI = 100$

Table 4. Monitoring Frquency, Voltage, Current, and active Power,3-phase induction motor $KP < KI$

PID	F (Hz)	T (s)	V (V)	I (A)	P (kW)
KP 1 KI 10	50	11	151	1	0.06
KP10 KI 100	49	175	152	1	0.08

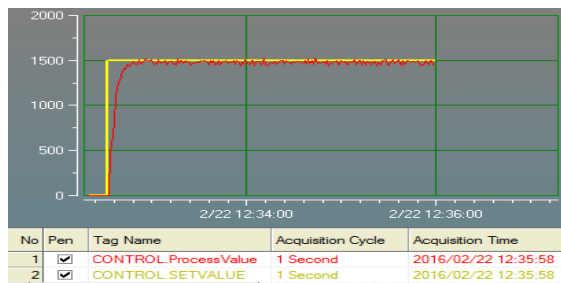

Figure 11. Graphic $KP=1$ $KI=10$

Table 5. Monitoring Frquency, Voltage, Current, and active Power,3-phase induction motor $KP > KI$

PID	F (Hz)	T (s)	V (V)	I (A)	P (kW)
KP 10 KI 1	50	6	151	1	0.06
KP100 KI 10	48	9	167	1	0.63

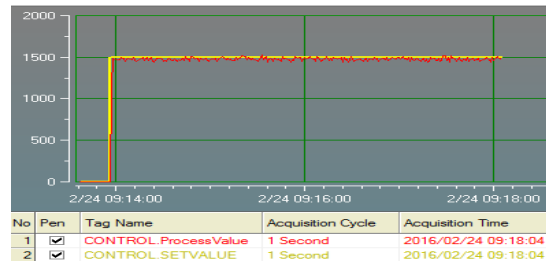

Figure 13. Graphic $KP=10$, $KI=1$

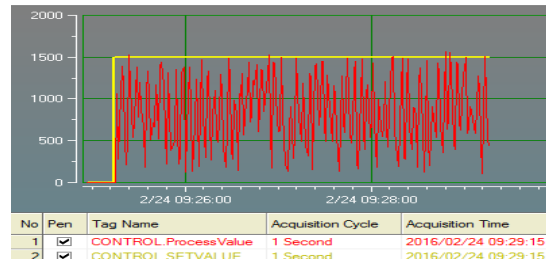

Figure 14. Grafik Nilai $KP=100$, $KI=10$

Table 6. Monitoring Frequency, Voltage, Current, and active Power,3-phase induction motor $KP < KI$ on the KP , KI , and KD composite

PID	F (Hz)	T (s)	I (A)	V (V)	P (kW)
PID=1	50	7	1	144	0.06
P100 I1 D1	50	5	1	150	0.06
P10 I100 D1	48	274	1	154	0.06
P1 I1 D100	39	-	3	158	0.89
P100 I1 D100	38	46	4	159	0.62
P1 I100 D100	25	600	3	147	0.55
P100 I100 D100	38	900	3	152	0.69

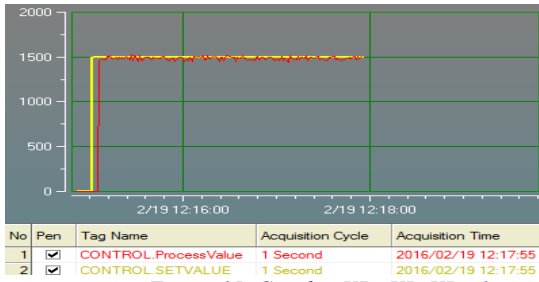

Figure 15. Graphic $KP=KI=KD=1$

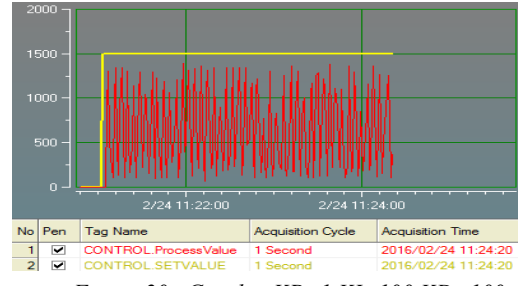

Figure 20. Graphic $KP=1$ $KI=100$ $KD=100$

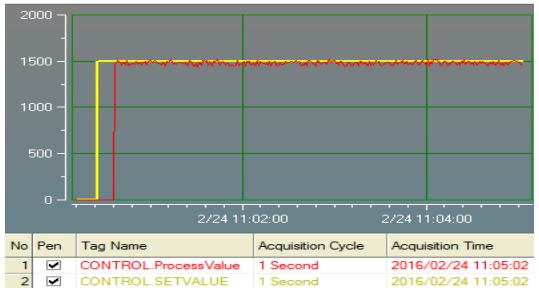

Figure 16. Graphic $KP=100$ $KI=1$ $KD=1$

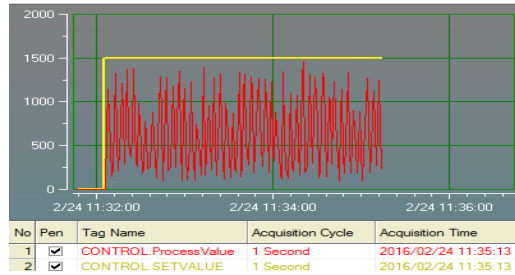

Figure 21. Graphic $KP=KI=KD=100$

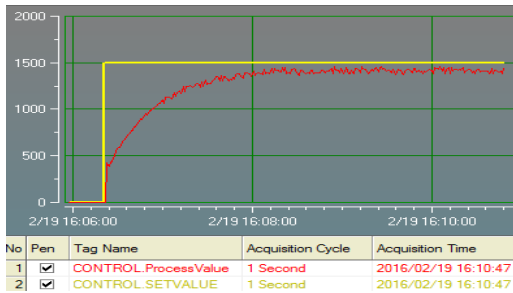

Figure 17. Graphic $KP=1$ $KI=100$ $KD=1$

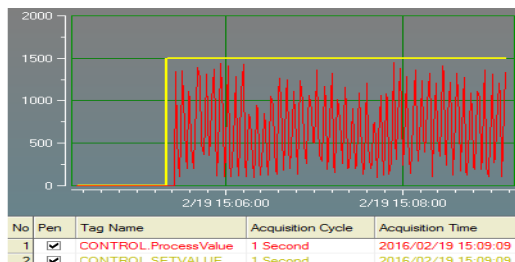

Figure 18. Graphic $KP=1$ $KI=1$ $KD=100$

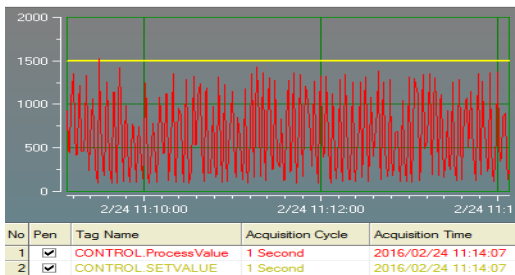

Figure 19. Graphic $KP=100$ $KI=1$ $KD=100$

On the close loop testing with the speed of 3-phase induction motor was set with SV = 1500 rpm. The effects of PID implementation on graphic response, frequency, time, current, voltage, oscillation, and power are explained :

1. KP, the higher the KP value was; the higher the fequency was, the faster the speed of PV reached SV value, the higher the Power and oscillation, and the more stabile the voltage and current were.
2. KI, if KI had so high value, the frequency would fall down, the voltage would be high, and current and power would become stabile. KI was applied to make PV rapidly getting SV value. Furthermore it could minimize the oscillation.
3. KD, if KI was more than 1, oscillation occured it could help PV to get SV value but it needed much time. The current, voltage, and power became higher but the speed of motor was not stabile.

5. CONCLUSION

Implementation of PID on the 3-phase induction motor could keep the speed of motor more stabile. It was showed on the SCADA INFOU. By the open loop test, oscillation became higher. Meanwhile on the close loop test, by setting the tuning PID on $KP = 1$, $KI = 10$ and $KD = 10$, oscillation could be minimized.

By controlling the 3-phase induction motor, tuning PID set on value $KP = 1$, $KI = 10$, $KD = 0$ could



improve the voltage (151 V), power (0.06 kW) whereas on the open loop test, they were lower. Moreover frequency and current were constant on 50 Hz and 1 A respectively.

REFERENCES:

- [1] Alrijadjis, Tanaka Kanya, and Nakashima Shota, "Intelligent Self-Tuning PID Controller Using Hybrid Improved Particle Swarm Optimization for Ultrasonic Motor", *Journal of Theoretical Applied Information Technology*, Vol. 66, No. 1, 2014.
- [2] Adhi Ksatria Theopaga, Achmad Rizal, and Erwin Susanto, "Design and Implementation of PID Control based Baby Incubator", *Journal of Theoretical Applied Information Technology*, Vol. 70, No. 1. 2014.
- [3] Khalid Grari, Jamal Bouchnaif, Mohammed Azizi, Hicham Fadil, and Anas Benslimane, "Sensorless Control of Switched Reluctance Motor with Fuzzy-PI Controller", *Journal of Theoretical Applied Information Technology*, Vol. 83. No. 1, 2016.
- [4] Saad Mohd Sazli, Hisha,Uddin Jamaluddin and Intan Zaurah Mat Darus, "Implementation of PID Controller Tuning Using Differential Evolution and Genetic Algorithms", *International Journal of Innovative Computing Information and Control*, Vol. 8, No. 11, PP 7761 – 7779, 2012.
- [5] Kanthaphayao Yutthana, Viboon Chunkag and Uthen Kamnarn, "Fuzzy Gain Scheduling of PI Controller for Distributed Controll of Parallel AC/DC Converters", *International Journal of Innovative Computing Information and Control*, Vol. 7, No. 12. PP 6757 – 6751, 2011.
- [6] Nurhayati, "Study Pengontrolan Motor Induksi 3 Fasa menggunakan PID berbasis INFOU", *Skripsi Universitas Halu Oleo*, 2013.
- [7] Sumiati ruzita, "Analisis Penggunaan Motor DC menggunakan Logika PID dengan Mikrokontroler ATMega 8535", *Jurnal Teknik Mesin*, Vol. 6 No.2, 2009.
- [8] Sulasno dan Thomas Agus Prayitno, *Teknik Sistem Kontrol*, Yogyakarta: Graha Ilmu, 2006.
- [10] Gaing Zwee Lee, "A Particle Swarm Optimization Approach for Optimum Design of PID Controller in AVR System". *IEEE Transaction On Energi Conversion*, PP. 1 – 9, 2014.
- [11] Setiawan Iwan, "Programmable Logic Controller (PLC)b dan Teknik Perancangan Sistem Kontrol", - Ed.1. – Yogyakarta : ANDI, 2007.
- [12] Petruzella D. Frank, "Industrial Electronics", Diterjemahkan oleh Sumanto, Yogyakarta: Andi, 1996.
- [13] Lee, Min Yoong, "LS XGT 0903 Manual Book". LS Industrial System, 2011.