



# THE HYBRIDATION ENTERS THE ORDERING OF THE SLIPPING MODE TO INTEGRAL ACTION AND THE FUZZY ORDER

( Application To The Permanent Magnet Synchronous Machine )

KECHICH ABDERRAHMANE<sup>1(\*)</sup>, MAZARI BENYOUNES<sup>2</sup>,

<sup>1</sup>Institut d'électrotechnique, B.P417 C .U. Béchar, Algérie ,Tel/Fax : 21349819024,  
e-mail : [akechich@yahoo.fr](mailto:akechich@yahoo.fr)

<sup>2</sup>Institut d'Electrotechnique, U.S.T.O. B.P1505, Oran El M'naouer, Algérie,Fax : 2136421581.

## ABSTRACT

This article presents a new approach to indirect vector control of permanent magnet synchronous machine. In this order the scrambled controller is added to the controller of sliding mode with integral action in order to guarantee the stability of the system. The new hybrid controller obtained is applied to the permanent magnet synchronous machine PMSM. In a first stage, we present the design of the order by fuzzy logic. This new order is applied to the PMSM. The second stage is devoted to the development of an order with variable structure. The latter is the order by sliding mode with integral action. In the third stage, we suggest a new scrambled controller of mode slipping for the ordering of position. In this case, the scrambled controller is added to the controller of sliding mode with integral action. We present the simulation results of the evolution of the real PMSM sizes, as well as the dynamic characteristics of the total system, during the starting of the PMSM. To justify our work, an evaluation of the two approaches is presented. Finally, the results of simulation prove that the system to be regulated is powerful and stable *vis-a-vis* the external disturbances.

**Keywords :** *Synchronous Machine, Permanent Magnet, Hybrid, Sliding Mode, Fuzzy Logic, Controller Structure .*

## 1. INTRODUCTION

The synchronous permanent magnet machine (Shortened later on PMSM) is a complex nonlinear system in which the parameters time-variables require an additional resolution [9]. The Methods of the vector control were proposed to simplify the speed control of these engines, thus they can be ordered like an enthralling machine of D.C. current. The indirect methods of vector control uncouple the current components from the engine by estimating the speed of slip, which requires a suitable knowledge of the time-constant of the rotor. Traditional systems such as the order PI, were employed, as well as the methods of the vector control [12], for the speed control of the PMSM. The principal disadvantages of the linear approach [8] of order are the sensitivity in the execution to the variations of the system parameters and the unsatisfactory rejection of the disturbances and the external changes of load. To

face these problems, the order with variable structure developed approaches, such as the order by sliding mode control SLMC [1], or the orders based on fuzzy logic FLC.

These new orders were recently applied to the order of the electric systems of drive [3]. SLMC, proved to be an effective manner to order the electric systems of drive. It is a robust order because the entry with high profit of feedback ordering countermands nonlinearities, parameters of uncertainty, and external disturbances. It also offers a fast dynamic response, a stable control device and an easy execution of material software. On the other hand, this strategy of order offers some disadvantages related to the great vibration of couple which appears in a state of balance, which can excite mechanical resonance. Logic known as 'blurred logical', initially proposed by L. A. Zadeh, recently caused much attention. The

scrambled controller was defined by rules with an obvious physical significance this helped to increase this technique of order. When it is applied to the nonlinear systems of order, this nonlinear strategy of order showed better results compared to the traditional controllers. However, stability in closed loop of the system is difficult to be guaranteed.

Recently, scrambled controllers of slipping mode were required and applied to the various systems; however, there are not many applications to the PMSM. In a controller of sliding mode with a surface of commutation the operation of integral was adopted to order the position of an ordering of servo-motor of induction in which a scrambled slipping mode controller of neurological network was applied. This last is employed to slacken the condition for the limits of uncertainties estimating such uncertainties in real time. One proposes in this study a new controller, it is a twinning of the two controllers: the first is based on the slipping mode with integral action, which functions in the transitory mode; the second functions during the permanent mode; that one calls the hybrid order.

**2. THE FUZZY ORDER**

**2. 1. Functions of membership**

Fuzzy logic is a technique of treatment of uncertainties and has as an aim: the representation of vague knowledge, it is based on current linguistic terms like small, large, average... etc. It authorizes intermediate values between truth and the forgery and admits even overlapping between them [4].

Vague unit: In a whole of reference a fuzzy subset of this reference, frame  $E$ , is characterized by a function of membership  $\mu$  and  $E$  in the interval of the real numbers [5] which indicates with what degree an element belongs to this class. A fuzzy subset is characterized by a core, a support and a height.

Core: It is the whole of the elements which are really in  $E : N(E) = \{x / \mu_E(x) = 1\}$

Support: It is the whole of the elements which are in  $E$  to differing degree:

Height: It is the upper limit of the function of membership  $ht(E) = Sup_{(x \in E)} \mu_E(x)$

A unit is known as 'standardized' if it is height 1:

Example: In Figure.1 an example of standardized subset is presented.

$$Supp(E) = [a, d]$$

$$noy(E) = [b, c]$$

$$ht(E) = 1$$

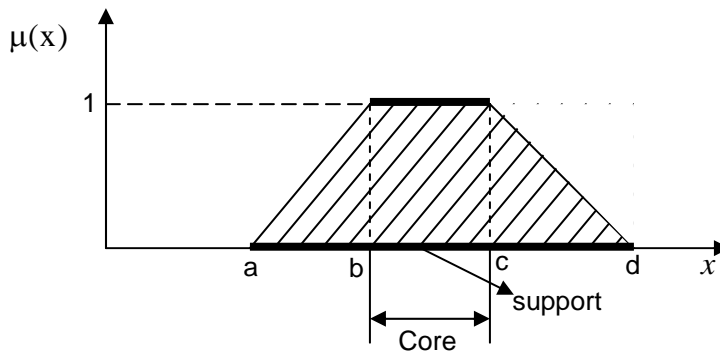

**Figure 1 : Format of a standardized vague unit.**

Operation: The possible operations on the vague sets are basic operations existing already in Boolean logic by respecting some properties.

Let  $A$  and  $B$  be a couple of universe of speech, a fuzzy relation,  $R$  between  $A$  and  $B$  is defined by:

$$A \times B \rightarrow [0,1]$$

$$(x, y) \rightarrow \mu_R(x, y)$$

The intersection: The intersection of two vague sets is the greatest vague unit contained in  $A$  and

in  $B$ :

$$\mu_{A \cap B}(x, y) = \mu_{AND}(x, y) = \min(\mu_A, \mu_B)$$

Union: A union of two vague sets  $A$  and  $B$  is the smallest vague unit containing  $A$  and  $B$

$$\mu_{A \cup B}(x, y) = \mu(x, y) = \max(\mu_A, \mu_B)$$

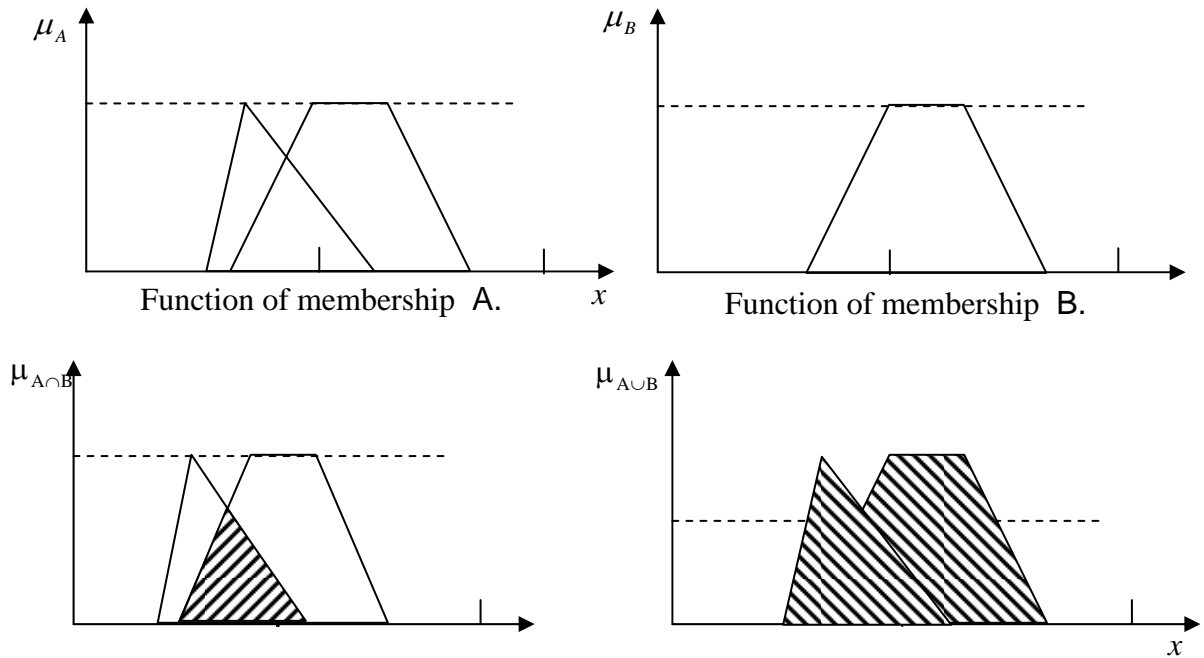

**Figure 2 :** Union and intersection of two fuzzy subset.

Complementation: The complementary of a fuzzy subset  $A$  in a whole of reference  $E$  is defined by the relation  $\mu_{\neg A} = 1 - \mu_A$ .

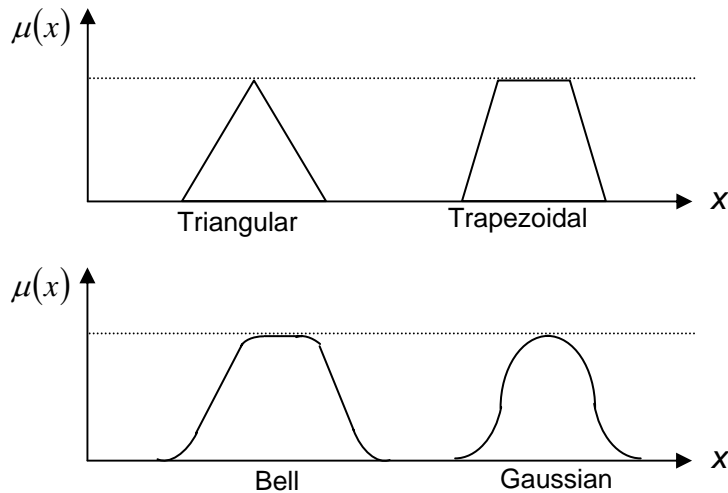

**Figure 3 :** Some typical functions of memberships.

**2. 2. Basic structures of a fuzzy controller**

In the fuzzy order several approaches can be used, these approaches are distinguished according to the entries and the exit from the controller.

Figure 4, represents a fuzzy controller of type PID, this last can be obtained by combining the two fuzzy controllers of type PI and PD [4].

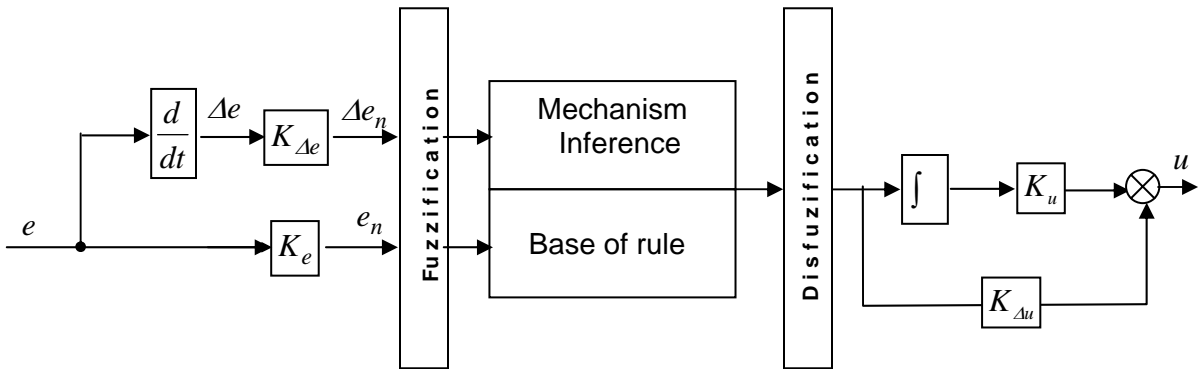

Figure 4 : General diagram of a standard fuzzy controller PID.

The profits  $K_e$  and  $K_{\Delta e}$  are named scale factors, they are used to transform the physical values of the entries (error and sum of errors) in a standardized field  $[-1, 1]$ . Moreover, the **denormalisation** changes the standardized value of the control signal to its physical field respected by using the two scale factors  $K_u$  and  $K_{\Delta u}$ .

Consequently, the entries of the fuzzy controller  $e_n$  et  $\Delta e_n$  are standardized by the use of the following expressions:

$$\begin{cases} e_n = K_e \cdot e \\ \Delta e_n = K_{\Delta e} \cdot \Delta e \end{cases}$$

(1)

In the same way, the exit  $u_n$  of the controller is **denormalised** with  $u$  by using the following relation:

$$u = K_u \cdot u_n + K_{\Delta u} \cdot \Delta u_n$$

(2)

2. 3. Fuzzification

In the field of control, the data observed is physical sizes generated by sensors. It is necessary to convert these real sizes into fuzzy variables. For that, one calls upon an operation known as fuzzification, which makes the degrees of the vague variable membership possible to its fuzzy subsets according to the actual value of the variable of entry [13] [14].

Each physical size being used must be standardized between -1 and +1.

In the case of the PMSM the variables of entries are the error of continuation and its derivative. The vague sets which form the universe of speech of each variable are:

NL: Negative Large; NS: Negative small; Z: Zero; PS: Positive Small; PL: Positive Large. The corresponding functions are illustrated on the Figures 5-a and 5-b the vague sets which form the speech of the variables universe of exit are:

NVL: Negative very large; NL: Negative Large; NM: Negative Medium; NS: Negative Small; Z: Zero; PS: Positive Small; PM: Positive Medium ; PL: Positive Large; PVL: Positive Very Large.

For a constant conclusion the corresponding singletons are given on the Figure 5-C.

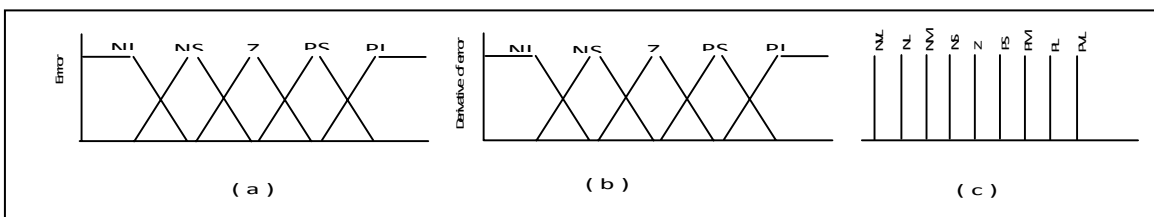

Figure 5 : Functions of membership of: (a)-the error of continuation (entry 1), (b)-the derivative of the error of continuation (entered 2), (c)-the conclusion (exit)



**2. 4. Base rules**

The system of vague control includes/understands a number of rules of inference connecting the entry vague variables of a system to the exit vague variables of this system. These rules arise in the following usual form:

If condition 1 and/or condition 2 (and/or...) then action on the exits. The establishment of these rules is generally based on the knowledge of the problem and the experiment of the operator. He can fix the number of subsets, their functions of membership as well as the linguistic variables. There are several presentations of the base of rules such as linguistic description, symbolic system or another by a matrix of inference [5].

**2. 5. Inference**

The inference, also called vague reasoning or approximate reasoning, is used in the vague rule to determine the result of the latter for values given to the variables of entry. In this block, the controller decides on an action similar to that of a human operator *vis-a-vis* a similar situation. This block includes, amongst other things, knowledge of the human expert of the dynamics and the characteristics of the system. Description of the inferences can be made by linguistic expressions, symbolic systems or by a matrix of inference. In the example of the ordering of the PMSM one proposes to use the strategy of order presented on the matrix of inference given by the following table:

$\tilde{x} \backslash \tilde{x}$	NL	NS	Z	PS	PL
PL	PS	NS	NL	NL	NVL
PS	PM	Z	NM	NM	NL
Z	PM	PS	Z	NS	NM
NS	PL	PM	PM	Z	NM
NL	PVL	PL	PL	PS	NS

**Tableau 1 :** Matrix inference.

**2. 6. Defuzzification**

The methods of inference generate a function of membership, it is necessary to transform this fuzzy size into a real physical size. The operation of defuzzification makes it possible to calculate starting from the degrees of membership of all the fuzzy subsets of the exit variable and the exit value to be applied to the system. There are several methods of defuzzification to know the method of the maximum, the method the balanced heights and the method of the centre of gravity. The latter is much used in several works for that we chose the use of this method in our work [8] [9]. The expression of the exit in this method is given by the following equation:

$$u = \frac{\int x \cdot u_R(x) \cdot dx}{\int u_R(x) \cdot dx}$$

(3)

**2. 7. Application to PMSM**

The application of this method of order respectively comprises the usual blocks of a fuzzy controller with *Ge, Gd, Gs*, i.e. the factors of the error scaling, of the derivative from the error and the control signal. These variables will be transformed into linguistic variables via a block of

fuzzification defined previously. The strategy of order is presented by a matrix of inference of the same type as that presented in Table1. The control signal is obtained by carrying out the

transformation of the conclusion into a physical quantity, with scaling at the exit of the block of defuzzification. The structure of order by fuzzy logic is given by the following diagram:

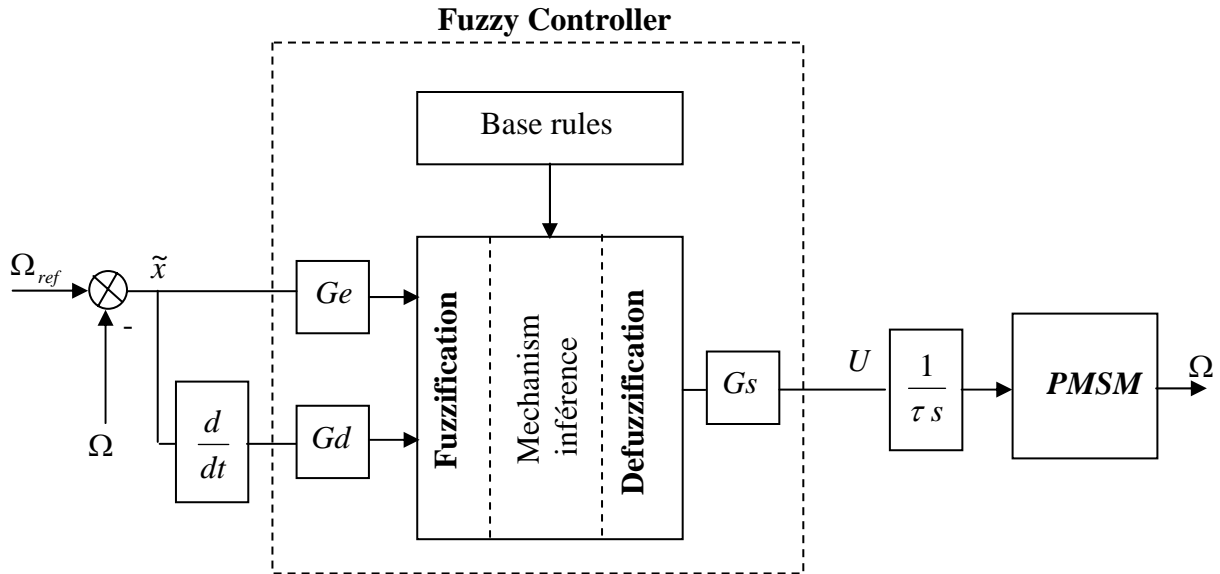

Figure 6 : Structure of order fuzzy logic of PMSM.

**2. 8. Simulation**

To evaluate the performances of the adjustment by logical controller fuzzy FLC, we carried out the stages of the following simulations, and that for a time of simulation  $t_{sim} = 2.5 [s]$ :

- \*- A loadless starting with a reference  $\omega_{ref} = 200 [rad/s]$ , for the speed regulation;
- \* - Application of a nominal load  $C_{rn} = 10 [Nm]$  and its elimination to the instants  $t = 0.5 [s]$  et  $t = 1 [s]$  respectively;
- \*- An inversion of the instruction with  $-200 [rad/s]$  for the speed regulation.

According to the results of simulations Figure 7 one notices an improvement of the total performance of the system with the insertion of the fuzzy regulator compared to traditional PI presented in Figure 8. During the starting and inversion of rotation direction, speed reaches its set point with a going beyond practically null. One remarks a good rejection of the disturbance due to the application and the elimination of the load. We notice that the adjustment by FLC gives good performances with respect to the continuation of the reference instruction without remarkable overtaking and a total rejection of the disturbance.

2. 9. Results of simulation in the case of the fuzzy controller

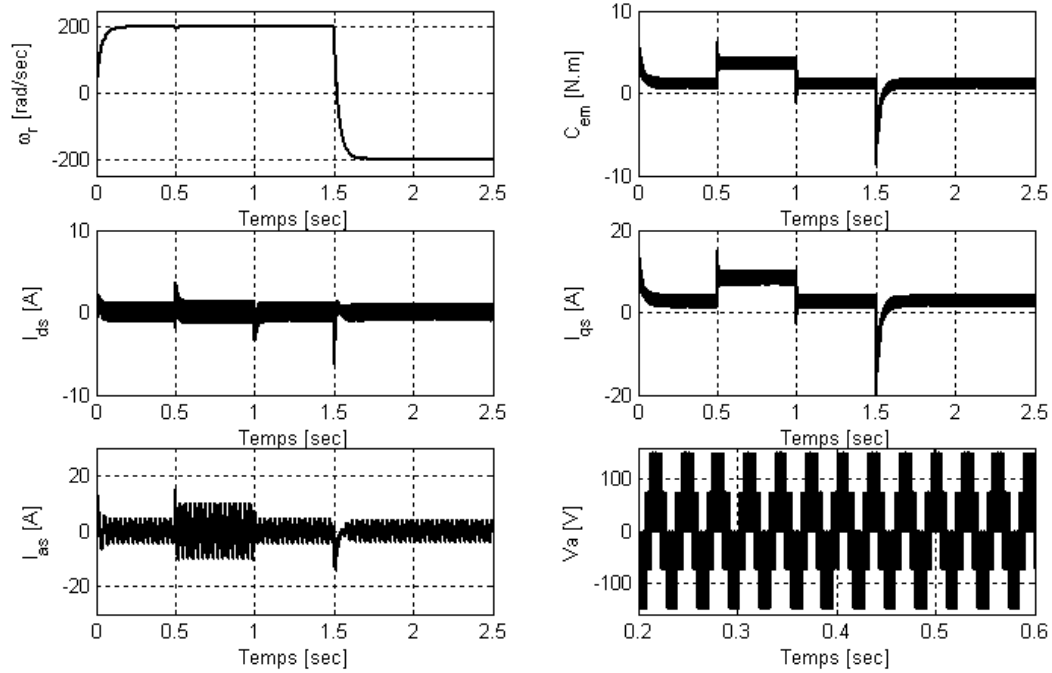

Figure 7 : Dynamic behavior for an instruction of 200 rad/s With application of the nominal load and inversion of rotation.

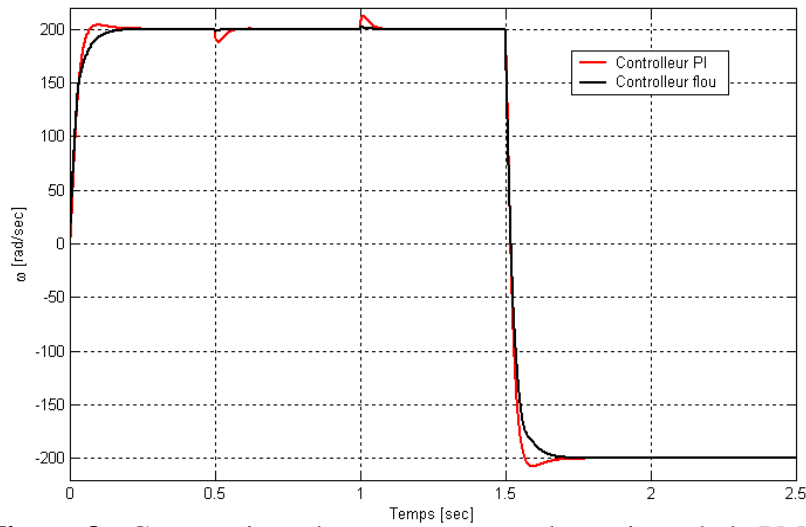

Figure 8 : Comparaison du comportement dynamique de la PMSM Dans la cas d'un contrôleur PI et un contrôleur flou (FLC).

3. THE ORDER BY SLIDING MODE SLMC

3. 1. Controller SLMC with integral action

In the order by slipping mode with integral action, an integral compensation can be inserted in order to decrease the vibrations from the phenomenon of chattering on the one hand and on the other hand it makes it possible to order without running up

against the couple, [2] [7]. The electromechanical equation which governs the evolution of the system was represented by the following equation:

$$\frac{d^2 \omega_m}{d^2 t} = \frac{k}{J \tau} u - \frac{B}{J} \dot{\omega}_m$$

(4)

The simplified variables of state are given by:

$$\begin{aligned} x_1 &= \omega_m - \omega_{ref} \\ x_2 &= \dot{x}_1 \end{aligned}$$

(5)

$$\begin{bmatrix} \dot{x}_1 \\ \dot{x}_2 \end{bmatrix} = \begin{bmatrix} 0 & 1 \\ 0 & -\alpha \end{bmatrix} \begin{bmatrix} x_1 \\ x_2 \end{bmatrix} + \begin{bmatrix} 0 \\ b \end{bmatrix} u$$

(6)

With:

$$\alpha = \frac{B}{J} \quad \text{and} \quad b = \frac{k}{J\tau}$$

The trajectory, whose SLMC forces the system to slip, is a straight line described by:

$$\sigma = \dot{x} + c x_1 = 0$$

(7)

The dynamics described by the equation (7) is a response of the first order with a definite constant 'c' of response speed. Various laws of order can be employed to force the reaction of system. We used the same speed controller of slipping mode, presented in [3], in which a variation is presented

in [4] what gave us a controller of position describes in the following equation:

$$u_{sl} = \psi_1 x_1 + \psi_2 x_2 + k_\sigma \sigma$$

(8)

Where,  $\psi_1$  and  $\psi_2$  are nonlinear functions definite in the form:

$$\begin{aligned} \psi_1 &= \begin{cases} \alpha_1, & \text{si } \sigma x_1 > 0 \\ \beta_1, & \text{si } \sigma x_1 < 0 \end{cases} \\ \psi_2 &= \begin{cases} \alpha_2, & \text{si } \sigma \dot{x}_1 > 0 \\ \beta_2, & \text{si } \sigma \dot{x}_1 < 0 \end{cases} \quad k_\sigma \in \mathbb{R}^- \end{aligned}$$

Where values:  $\alpha_1, \alpha_2, \beta_1, \beta_2$  et  $k_\sigma$  are constants.

The control signal is produced by a combination of the linear and nonlinear limits. The term  $k_\sigma \sigma$  was added to provide the robustness of system without producing the undulation of torque mainly when the control of the action of order is large [5].

### 3. 2. Results of simulation of the sliding mode with integral action

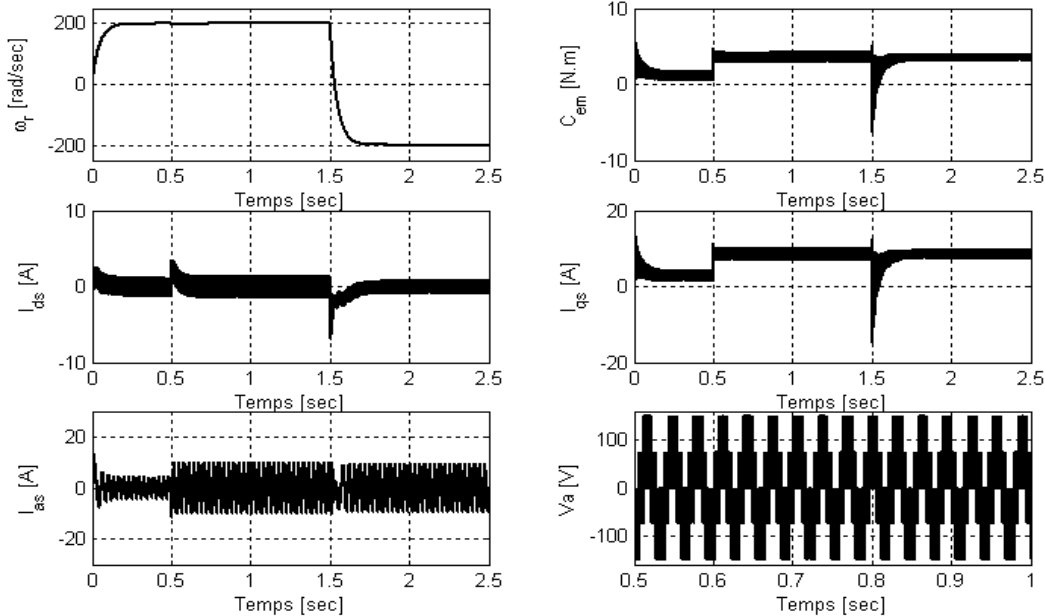

**Figure 9 :** Dynamic behavior for an instruction of 200[rad/s] with application of the nominal load and inversion of rotation. Case of regulator SLMC to integral action.



**4. THE HYBRID ORDER**

**4. 1. Design of the new controller**

One introduces a new scrambled controller of sliding mode for the speed regulation of the PMSM ordered by indirect vector. This method combines two controllers SLMC and FLC. The SLMC with integral action acts in most of the time in a momentary state, providing a fast dynamic response and increasing the limits of stability of the system, while the CLF acts mainly in the state of balance to reduce the vibrations. If we compare this approach to a traditional controller PI, the

balanced execution is increased [10] [14]. An expert system based on the scrambled reasoning is employed to compare the exits obtained starting from the two nonlinear controllers to obtain the action of order. By using this structure, better executions are realized when using controller SLMC with integral action only or the FLC alone. In this case, total stability is also assured. The total analysis of stability will be shown later (in the next article).The effectiveness of this control method is shown and checked [5].

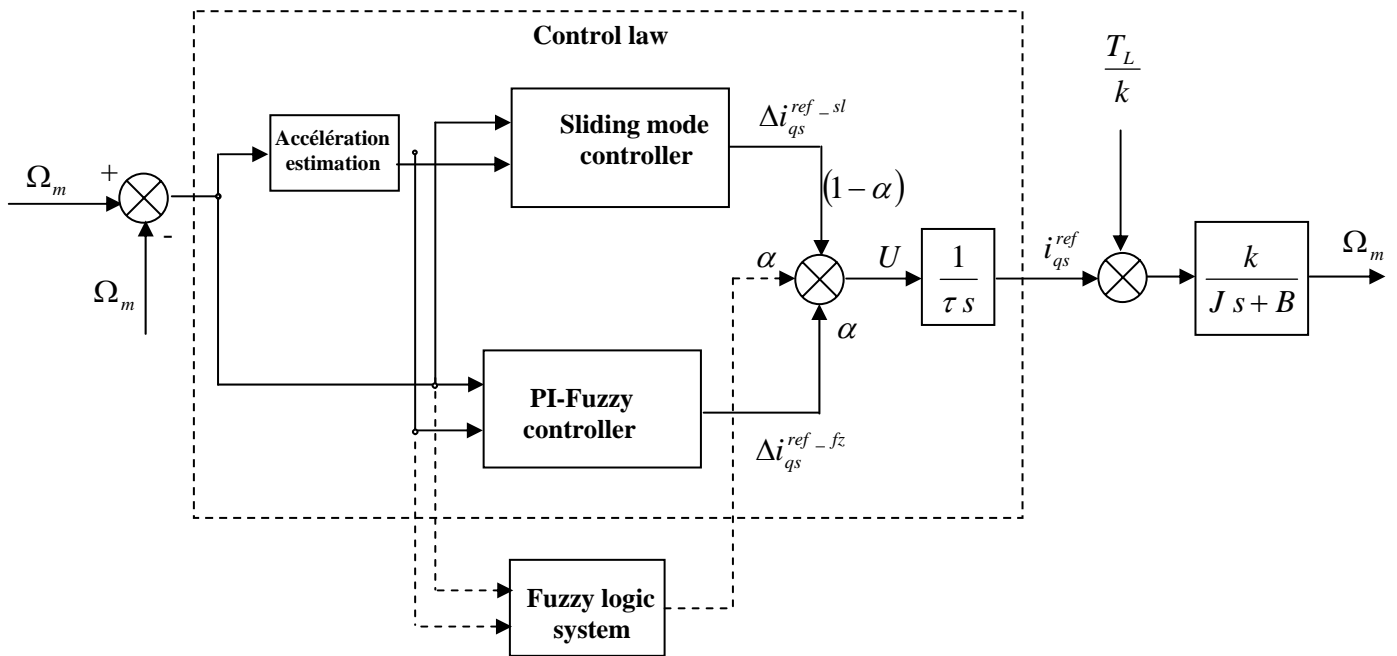

**Figure 10 :** Hybrid order diagram FLC-SLMC with integral action.

**4. 2. Commutated Model of Control Device of the PMSM**

The structure of the control device is shown in Figure 10. The indirect method of control of vector is employed and the component of the stator current flow  $i_{ds}^{ref}$  is maintained constant, although it is not a restriction.

The output of the controller proposed is the desired component of the torque and the stator current  $i_{qs}^{ref}$

The electromagnetic torque  $C_e$  is proportional to this component current.

$$C_e = k i_{qs}^{ref} \tag{9}$$

(9)

The model ordered by vector of the PMSM can be expressed by the equation:

$$\frac{d\omega_m}{dt} = \frac{1}{J} (k i_{qs}^{ref} - C_l - B \omega_m) \tag{10}$$

- Where:
- $J$  : Inertial constant ;
  - $k$  : Proportional torque constant ;
  - $B$  : The constant of friction;

$T_l$  : Load torque;

$\omega_m$  : Measured speed.

The model is a model of first order and is shown by transformation of Laplace in Figure 10. To obtain the law of order, the SLMC with integral action and PI-FLC are separately conceived particularly to obtain good characteristics in the state where each one provides the reigning action of order. Afterwards, they are adjusted to carry out the satisfactory devices when they are combined. The error between desired speed  $\omega_{ref}$  and measured speed  $\omega_m$  and the change of this error are the entries with the two controllers. The actions of order are combined by means of a factor ( $\alpha$ ) heavy, which is the output of a system of fuzzy logic which functions on a higher hierarchical level of order.

It divides the area of order according to the error speed and the change of the error. The final action  $i_{qs}^{ref}$  is established in the equation (11).

$$\begin{aligned}
 u_{sl} &= \Delta i_{qs}^{ref-sl} \\
 u_{fz} &= \Delta i_{qs}^{ref-fz} \\
 u &= \Delta i_{qs}^{ref} = \alpha u_{fz} + (1 - \alpha) u_{sl} \\
 i_{qs}^{ref} &= \frac{1}{\tau} \int_0^t \Delta i_{qs}^{ref} dt
 \end{aligned}
 \tag{11}$$

(11)

Where:

$\Delta i_{qs}^{ref-sl}$  : Output variable of the SLMC;

$\Delta i_{qs}^{ref-fz}$  : Out put variable of the FLC ;

$u$  : Represents the general activity of order before the integrator;

$\tau$  : Represents the control action integration constant .

This equation gathers the output of the SLMC with integral action and the output of the FLC.

### 4. 3. The Scrambled Monitoring System

The monitoring system scrambled is employed to calculate the value ( $\alpha$ ). The area of order is divided using a machine of scrambled inference, imilar to that previously described, and that acts on the hierarchical highest level of the order [8].

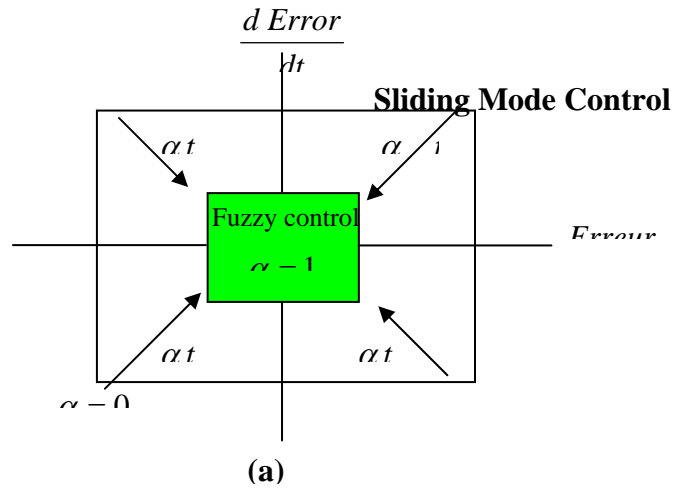

The Figures 11-a and 11-b show the structure of the hierarchical law suggested in this order. The Figure 11-a depicts the two areas of order. As one can see, the objective of the supervisor is to change the value of ( $\alpha$ ). When an error and its derivative, with regard to time in absolute value are small, the scrambled controller must be dominating ( $\alpha=1$ ). In the opposed case, the controller of the sliding mode with integral action is dominating. The Figure 11-b shows the machine of scrambled inference of monitoring. As represented on Figure 11 the functions of adhesion are the triangular ones and the functions of output are of Singletons.

The definitions of the symbols are:

Very large (VL), large (L), (M) medium, small (S) and (Z) zero.

Rules in this figure are defined by a table, for example, a rule in the table can be stated as follows: " If the absolute value of the error is the average value and the derivative of the absolute error are large, then ( $\alpha$ ) is equal to zero." Once that the value ( $\alpha$ ) is obtained the final action of order ( $u$ ), is determined by the equation (11).

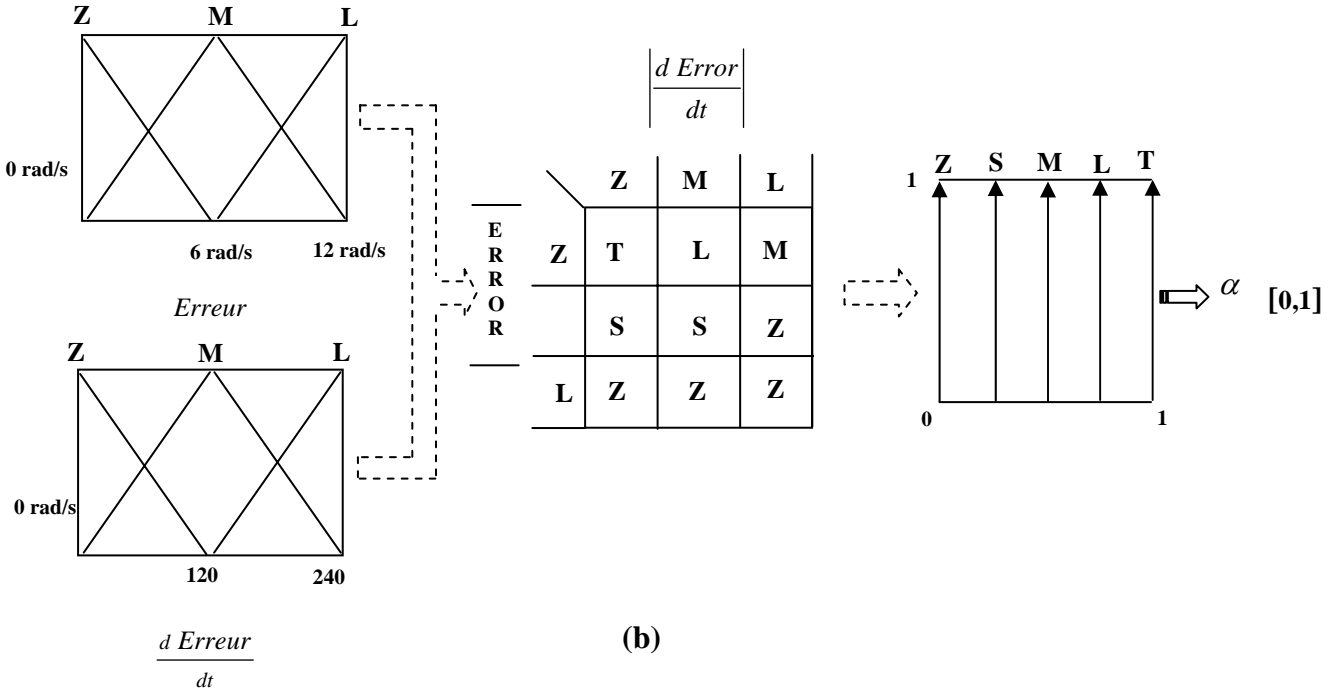

**Figure 11** : Hierarchical structure of the order:  
 a- Control regions.  
 b- Machine of scrambled inference.

**4. 4. Simulation**

To evaluate the performances of adjustment FLC-SLMC to integral action, we carried out the following stages of simulations, for a time of simulation  $t_{sim} = 2.5$  [s]:

- \* - A loadless starting is with a level of reference  $\omega_{ref} = 200$  [rad/s], for the speed regulation.
- \* - Application of a nominal load  $C_{rn} = 10$  [Nm] and its elimination to the moments:  
 $t = 0.5$  [s] and  $t = 1$  [s] respectively;
- \* - An inversion of the instruction with  $-200$

[ rad/s ] for the speed regulation.

According to the results of simulations Figure 12 we notice an improvement of the total performance of the system compared to regulator SLMC with integral action, see Figure 9. During the starting and inversion of direction of rotation, speed reaches its set point without going beyond. A good rejection of the disturbance is due to the application and the elimination of the load. We notice that the adjustment by the FLC-SLMC with integral action gives good performances with respect to the continuation of the instruction of reference without going beyond.

#### 4. 5. Results of simulation of the hybrid order

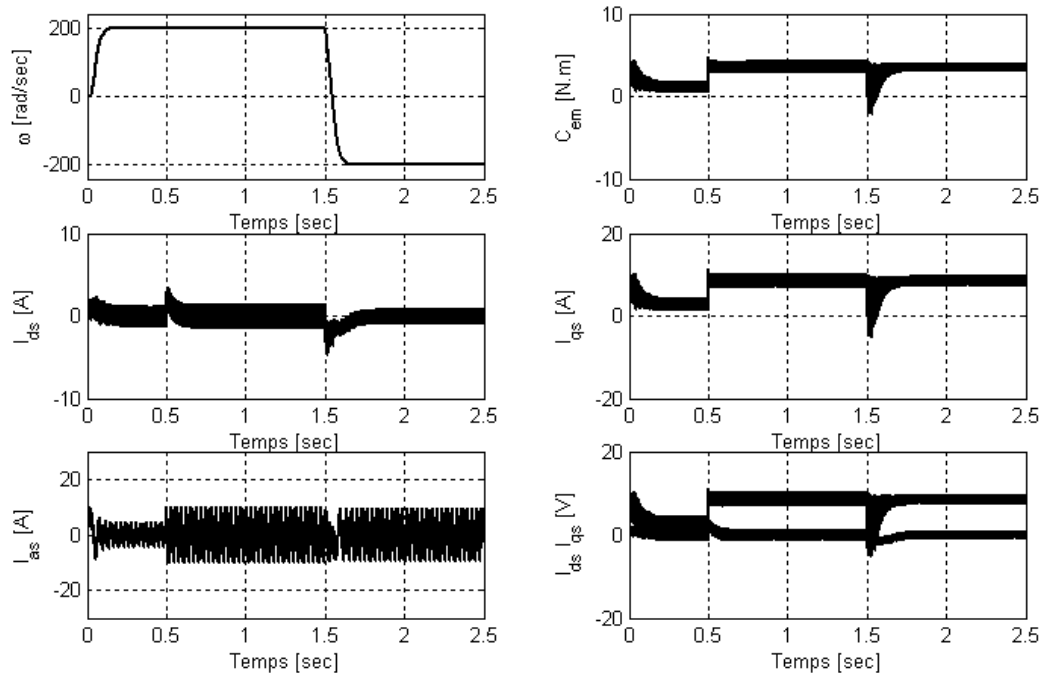

**Figure 12 :** Dynamic behavior for an instruction of 200 [rad/s] with application of the nominal load and inversion of rotation. Case of regulator FLC-SLMC with integral action.

## 5. RESULTS AND DISCUSSION

### 5. 1. Evaluation of the two approaches ( fuzzy Logic and sliding mode )

\* - One of the disadvantages related to the high profit inherent in the methods of the slipping mode is the great vibration of torque due to the ordering sliding law of commutation mode. One of the causes which of this phenomenon is the presence of the time which delays calculations of order [9]. Another cause is the limitations of the physical releases which cannot commute the current at an infinitely fast speed. Although it is particularly apparent in the state of balance, it also exists when the system approaches this state.

Thus, an integral compensation can be inserted in order to decrease the vibration and to allow the order without running up against the torque [5] [7].

\* - The principal disadvantage of the systems ordered by fuzzy controller PI-FLC is the difficulty of the systems stability in transitory

mode. However, this kind of order showed excellent results, particularly once confronted in experiments with the nonlinear control devices.

\* - Fuzzy controller PI-FLC provides a soft execution by reaching a state of balance. A similar system was employed in other works presented by other researchers.

\* - The scrambled controller, whose rules are depicted in Figure 11 is adapted by changing the factors of graduation of the entry variables to obtain the execution in closed loop desired of the system when the latter is close to the balanced behavior.

\* - In this approach one employed, for the FLC, the rule of operation of product. The connection is applied by means of the operation minimum. Scrambled rules are combined by means of the



connection which is applied by means of the algebraic addition, too.

\* - In this present work one has to take the two advantages of both controllers. The first controller SLMC, works in the transitory mode as for the second FLC, it works with the mode permanent.

\* - We compared our approach with that of our colleagues [5], it proved that the two operations converge in the same direction in case the results give good continuation of the instruction in the two modes, transient and permanent.

## 5. 2. Characteristic of the error according to the derivative of the error

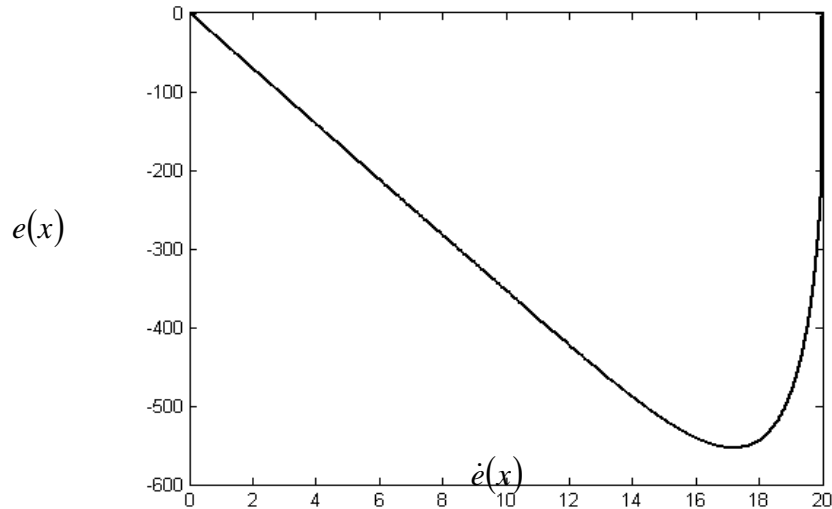

**Figure 13 :** Characteristic of the error according to the derivative of the error. Case of mode FLC-SLMC with integral. action

## 6. CONCLUSION

A new hierarchical controller based on scrambled inference is introduced. The suggested order structure combines a controller sliding mode with integral action and a controller based on fuzzy logic. The first based on the theory of the sliding mode with integral action which has the advantage of being robust with respect to uncertainties and disturbances. The second uses fuzzy logic allowing decreasing the abrupt variations of the control signal and the static error. The action of order is weighed between two basic nonlinear controllers with a machine of scrambled inference which provides a scrambled division of the area of order. The dynamics of ordering of the hierarchical structure suggested was studied in experiments. The experiments prove that the dynamic response of the system using the controller proposed is better if compared to a traditional controller PI. Moreover, in the state of balance; the vibration of the torque is decreased in comparison to a controller of SLMC with integral compensation.

In conclusion, the method suggested provides the improvement of robustness of drive and ensures total stability in relation to the controller of FLC.

## REFERENCES

- [1] Utkin, V. I., 1977, "VSS with sliding mode," IEEE Trans – automat, Control., 22(2), pp. 212-222.
- [2] Slotine, J. J., 1984, "Sliding Controller design for nonlinear systems," IJC., 1(2), pp. 421-434.
- [3] Ho, E.Y., and Sen, P. C., 1991, "Control dynamics of speed drive systems using sliding-mode controllers with integral compensation," IEEE Trans. Ind. Appl., 27(5), pp.25-30.
- [4] Bühler, H., 1996, "Réglage par mode de glissement," Première édition ISBN2-88074-108-4, (presse polytechniques romandes.), CH-1015 Lausanne.



- [5] Galvan, E., Toralba, A., and Franquelo, L. G., 1997, "ASIC Implementation of a digital tachometer With high precision in a wide speed range," *IEEE Trans. Ind. Electron.*, 44(3).
- [6] Wai, R. J., and Lin, F.J., 1999, "Fuzzy neural network sliding-mode position controller for induction servo motor drive," *Proc. Inst. Elect. Eng. Elect. Power Application.*, 146(3), pp. 297-308.
- [7] Barrero, F., González, A., Galvão, E., and Franquelo, L. G., 2002, "Speed Control of Induction Motors Using a Novel Fuzzy Sliding-Mode Structure," *IEEE Transaction on fuzzy systems.*, 10(3), pp. 375-383.
- [8] Xu, X., Lee, J., and Pan, Y. J., 2003, "On the sliding-mode control for DC servo mechanisms in the presence of unmodelled dynamics," *Mechatronics.*, 13(1), pp. 755-770.
- [9] Azizur Rahman, M., Mahinda Vilathgamuwa, D., Nasir Uddin, M., and Tseng, K., 2003, "Nonlinear Control of Interior Permanent-Magnet Synchronous Motor," *IEEE Transaction on Industry Application.*, 39(2), pp. 408-414.
- [10] Wang, Y., Wang Z., Yang, J., and Pei, R., 2005, "Speed regulation of induction motor using sliding mode control scheme," *IAS meeting, IEEE conf.*, pp. 72-76.
- [11] Valentin, C., Magos, M., and Maschke, B., 2007, "Nonlinear analysis: Hybrid Systems and Application," 122(4), pp. 106-122.
- [12] Morel, F., Retif, J., Lin-shi, X., and Valentin, C., 2007, "Permanent Magnet Synchronous Machine Hybrid Torque Control," *IEEE Transaction on Industrial Electronics, Numero special* pp. 7-31
- [13] Maciala, M., Ghribi, M., and Kaddouci, A., 2007, "Fuzzy-logic Based Frequency and Output Power Control of Power Systems," *GESTS International Transaction on computer science and engineering.*, 37(1), pp. 174-186.
- [14] Benabou, A., George, S., and Clenet, S., 2008, "Permanent Magnets Modelling for Dynamic Application," *Journal of Magnetism and Magnetic Materials.*, 320(6), pp. 830-835.