



PERFORMANCE EVALUATION OF MULTI USER DETECTION FOR UPLINK WIRELESS COMMUNICATIONS WITH VARIOUS MULTIPLE ACCESS SCHEMES

¹S.TAMIL SELVI, ²K.RAMAR

¹Associate Professor / ECE, National Engineering College, Kovilpatti, Tamilnadu, India

²HOD / CSE, National Engineering College, Kovilpatti, Tamilnadu, India

E-mail: tamilgopal2004@yahoo.co.in

ABSTRACT

The growing demand for capacity in wireless communications is the driving force behind improving established networks and the deployment of new worldwide mobile standard. Multiple Access Interference (MAI) and Inter Symbol Interference (ISI) limit the capacity of the system. The conventional approaches for wireless communication may not be good in many ways. Here, a proposal has been given to show that the problems in conventional approaches may be avoided, if the proposed Parallel Interference Cancellation (PIC) multi user detection with feedback (PICF MUD) is adopted in various multiple access schemes. In DS-CDMA system using PIC receiver with four stages, the E_b/N_o required to achieve a BER performance of 10^{-3} is 8 dB, whereas the single stage PIC receiver with feedback approach requires only 2 dB to achieve the same BER. The proposed PICF MUD is extended in various multiple access systems to provide better BER performance.

Keywords- *Multiple access schemes, multi user detection, multiple access interference, DS-CDMA, multi carrier Interleave Division Multiple Access, OFDM, SDMA*

1. INTRODUCTION

The ever-increasing appetite for capacity and data rates has motivated the emergence of new Multi User Detection (MUD) techniques and multiple access schemes in wireless communication. While traditional single user detection schemes assume all other users' signals to be white noise, MUD utilizes some known information of the other users to perform symbol detection for the desired user. Potential for improved performance through joint detection of multi user signals, coupled with associated challenges in achieving this potential at affordable receiver complexity, has motivated the research in the area of multi user detection.

The optimum MUD complexity, which is exponential in the number of users, has inspired a considerable effort toward the development of low complexity, sub-optimal alternatives capable of resolving the detrimental effects of multiple access interference (MAI). The performance of linear Parallel Interference Cancellation (PIC), non-linear PIC and Hybrid Interference Cancellation

(HIC) have been discussed in [1], [2], [3]. In non-linear PIC, each user receives equal treatment in canceling multiple user interference, which cancels the estimated MAI for all users simultaneously. Performance of DS-CDMA system is mainly limited by MAI and ISI. Interleavers can be employed to distinguish signals from different users and the scheme is referred to as Interleave-Division Multiple-Access (IDMA). IDMA can be regarded as an improved version of CDMA by treating interleaving index as multiple access codes. A Space Division Multiple Access (SDMA) is a multiple access technique which enables two or more subscribers, affiliated to the same base station, to use the same Time, Frequency and Code (T/F/C) resources on the grounds of their physical location or spatial separation. With SDMA, cell users within the system would be able to communicate at the same time using the same channel [12].

The paper is organized as follows. In section II, proposed multi User Detection is described. The IDMA with proposed MUD is discussed in section III including MC-IDMA and MC-MC-IDMA.

Section IV deals with the evaluation of proposed MUD in OFDM-SDMA system. Finally, simulation results demonstrating the BER performance of various multiple access systems using the proposed MUD are presented in section V.

2. PROPOSED MULTI USER DETECTION IN DS-CDMA

The uplink multiple scenario is considered, where each user (transmitter) and the base station (receiver) has single antenna. The channel is assumed to be flat fading channel. The multi stage PIC detector [4] in base station, each stage requires conventional detector, spreader and partial summer to estimate the data. In each stage it estimates the data simultaneously for all users. The estimated data from the previous stage is given as input for the next stage. The complexity of the system increases as the number of users and the number of stages increases. Hence the conventional PIC detector is modified to improve the performance of the system with reduction in complexity. The steps involved in the proposed PIC are as follows:

- Step1: Obtain the initial estimates from the matched filter (conventional filter)
 Step2: Spread the signal with its unique Gold sequence
 Step3: Obtain the partial-sum output (sums up all but one input signal for each user i.e., MAI)
 Step4: Subtract MAI seen by each user from the received signal
 Step5: Obtain the estimated data after matched filter and demodulation process.
 Step6: Calculate the BER
 Step7: If $BER > \text{target BER}$, goto step 1 (with PIC detector estimates) otherwise goto step 8.
 Step 8: End

The simplified block diagram is shown in fig.1. Here, initially the switch is closed. The PIC detector estimates the signal and the BER are calculated. If the BER is not satisfied, the estimate of PIC detector is given as input to the PIC detector. Now the switch is opened and the detector estimates are iterated through the same PIC detector.

This process (iteration) continues until the BER reaches the target BER or the process is terminated when there is no significant change from the previous iterations. For further processing of blocks of received signal, the switch is closed and the same procedure is repeated.

The DS-CDMA system is simulated using PIC detector with multiple stages and single stage PIC detector with feedback MUD (PICF MUD). The simulation results show that the performance of PICF MUD is better than conventional PIC detector with multiple stages.

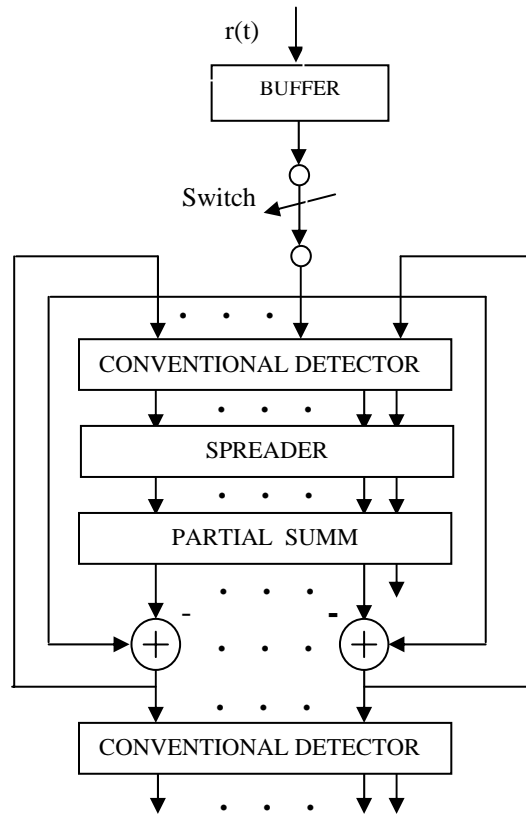

Figure 1. Simplified proposed PIC detector with feedback (PICF MUD)

3. PROPOSED IDMA USING PICF MUD

Conventional CDMA relies on spreading sequences for user separation and conventional IDMA [6] relies on chip-level interleavers to distinguish users. In the proposed IDMA, the receiver distinguishes the user only if it knows both spreading codes and interleaving index of that user. Different Gold sequences are used as the spreading codes for each user. Random interleavers are used for different users. The PICF MUD is employed at the front end of the multi user receiver.

3.1. Multi Carrier IDMA (MC-IDMA) systems

Future generation of wireless systems (4G) require higher data rates and greater flexibility. This will necessitate the use of a transmission scheme, Multi Carrier (MC) that can accommodate



very high data rate transmission over the hostile wireless channel. The idea of a hybrid communication scheme combining multi-carrier and IDMA has recently been proposed in [7]. The MC-IDMA scheme is an extension of MC-CDMA and inherits many attractive features, such as the simple treatment of ISI and effective mitigation of cross-cell interference. MC-IDMA is robust against multipath fading and mitigates the difficulty of equalization for frequency selective channels. MC-IDMA is widely regarded as a promising candidate for the implementation of physical layer in the fourth generation (4G) wireless communication systems.

The proposed MC-IDMA involves signature sequences with short code and unique interleave index, supports multiple users. In MC-IDMA, upon allocating a sub carrier bandwidth which is lower than the channel's coherence bandwidth, multi-carrier techniques become capable of transforming a frequency selective fading channel into a frequency-flat fading channel for each sub-carrier. This can be achieved even in case of high data rates and highly dispersive channels. MC-IDMA systems along with multi user detection become capable of supporting a large user population. A significant amount of research work has been spent on the MC-IDMA schemes.

3.2. Multi-code Multi Carrier IDMA (MC-MC-IDMA) system

The integrated networks need to provide a variety of sophisticated services, which have different requirements on bandwidth and data rates. Moreover, wireless systems will have to employ techniques to overcome fading effects of the channel. A novel multi-code system has been proposed in [8], [9] to support variable data rates. In this scheme, each user has a set of M codes called the sequence set. The system is an M -ary modulation, where a code sequence represents a sequence of $\log_2 M$ bits. The size of the sequence set depends on the required data rate. In the normal case, the set size is 2, i.e., there are two sequences in the set, one to represent a '0' and one to represent a '1'. When the data rate is to be made L times the standard data rate, then the sequence set is made of size 2^L and each sequence of L bits is mapped to one of the 2^L code sequences.

Depending on the required data rate, each user has a set of M code sequences, where M is the ratio of the base data rate and the required data rate. The base data rate is achieved with a set of just two sequences. The M -ary symbol to be transmitted

selects one of the code sequences of length N , which is then multiplied chip-wise with the user specific sequence. The user-specific is a PN sequence of the same length N as the code sequences.

At the receiver, the proposed PICF MUD is used to detect the transmitted symbol. The received code sequence is first multiplied chip-wise with user sequence and the resultant is correlated with each of the possible M code sequences. The sequence that gives maximum correlation is then mapped back into an M -ary symbol.

4. OFDM-SDMA SYSTEM USING PICF MUD

SDMA system is implemented using multiple elemental antenna arrays at the base station (BS) instead of a single omni-directional antenna. The array is designed so that each of the antenna elements picks up a reasonably uncorrelated signal with respect to the other antenna elements in a multi-path environment. Then, some level of intelligence is given to the system so that it can extract the signal of the desired user and null out all other users or interferences. Using SDMA, it is possible to increase the capacity of a cellular mobile radio system by taking advantage of spatial separation between users [10], [12].

Two major obstacles toward high capacity of future wireless systems are the channel distortion and the inefficient bandwidth usage. While Orthogonal Frequency Division Multiplexing (OFDM) provides the low cost solution to the channel distortion, SDMA, a spectrum efficient technique, provides the spatial dimension for multiple users to share the same frequency band simultaneously. An OFDM system combined with SDMA is considered as a spectral efficient transmission scheme [13], [14], [15].

Detection techniques typically employed in CDMA systems, such as Zero Forcing (ZF) and Minimum Mean Square Error (MMSE) detection [5] (linear detection schemes), Successive Interference Cancellation (SIC) and Parallel Interference Cancellation (PIC) (Non-linear detection schemes), Maximum Likelihood Detection (MLD) and Maximum Likelihood Sequence Estimation (MLSE) have recently been tailored to support the operation of SDMA systems [17]. Previous works have shown that MLD has the best Bit Error Rate (BER) performance compared to other detection schemes. However, MLD is prohibitively complicated to be applied in practical systems. Thus, it is important to find an efficient

algorithm saving the receiver complexity with small degradation in performance.

In OFDM-SDMA system, PIC with feedback MUD algorithm (PICF MUD) is employed in the SDMA processor in the receiver side and OFDM is employed in the transmission side.

5. SIMULATION RESULTS

The uplink wireless communication system is simulated with various multiple access schemes. The simulation results are presented in demonstrating the performance of the proposed MUD in various multiple access systems in flat fading channel.

5.1. DS-CDMA system

In the uplink, the receiver at the base station is simulated using PIC detector with feedback MUD (PICF MUD) using BPSK demodulation. The BER performance of the conventional detector, conventional PIC detector and PIC with feedback detector are compared and depicted in the fig.2.

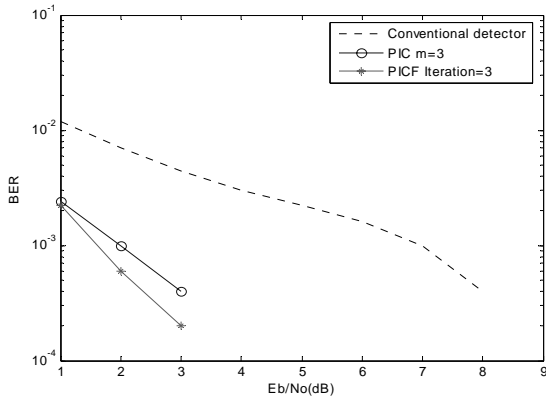

Figure 2. Performance comparison of conventional detector, conventional PIC with 3 stages, PICF MUD with three iterations (No. of users=10 and Gold sequence length=31) over AWGN channel.

Fig.2 shows that the performance of the PICF MUD is better than the conventional PIC detector with multiple stages and conventional detector. The figure also shows that PICF MUD receiver attains the target BER with three iterations itself at E_b/N_o of 4 dB.

5.2. SC-IDMA system

The IDMA system is simulated with single carrier frequency for transmission of signals. A data length of 1000 bits per user is used for simulation. The performance of PICF MUD is evaluated in DS-CDMA and SC-IDMA systems. Fig.3 shows that the target BER is achieved with low E_b/N_o (3 dB less) in SC-IDMA system when compared to DS-CDMA system. The BER performance of SC-IDMA is better than the performance of DS-CDMA system.

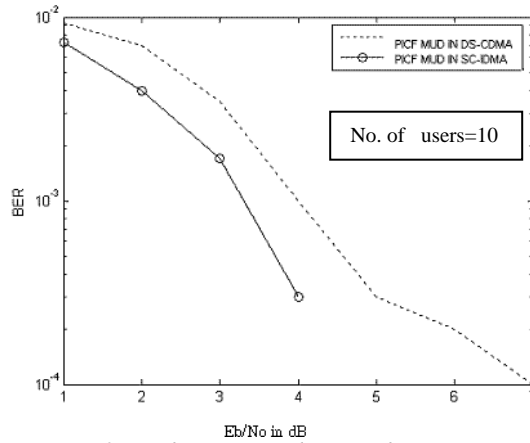

Figure 3. Performance evaluation of PICF MUD in DS-CDMA and SC-IDMA systems over Rayleigh fading along with AWGN channel (No. of users=10)

5.3. MC-IDMA system

The MC-IDMA system is simulated with multi carrier transmission and PICF MUD at the receiver. The performance is compared with other MUD techniques as shown in fig.4.

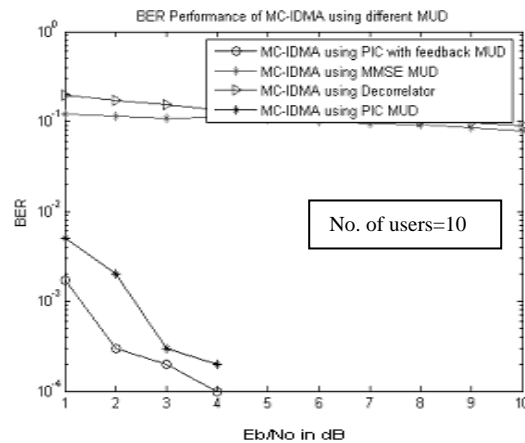

Figure 4. Performance of MC-IDMA with different MUD over Rayleigh fading along with AWGN channel

The following parameters are used in the simulation of system with MUD techniques. Data

length =100 bits/user, BPSK modulation, No. of iterations=3, No. of sub carrier =2, No. of simultaneous users = 10. The figure shows that the system using PICF MUD with three iterations provide better BER performance compared to other detectors such as MMSE, decorrelator and PIC MUD. From this figure it is observed that, in PICF MUD the BER performance of 10^{-4} is achieved with 4 dB itself compared to other MUD techniques.

The proposed PICF MUD is evaluated in DS-CDMA, SC-IDMA and MC-IDMA system and their BER performances are compared and depicted in fig. 5.

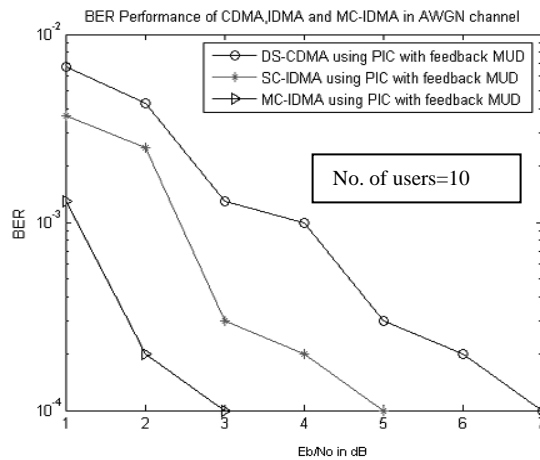

Figure 5. Performance of DS-CDMA, SC-IDMA and MC-IDMA using PIC with feedback MUD over AWGN channel

The figure shows that the BER performance of MC-IDMA is better than SC-IDMA and DS-CDMA using PICF MUD. From this figure, it is observed that, in MC-IDMA, BER performance of 10^{-4} is achieved with E_b/N_o of 3 dB itself whereas in the other two schemes it requires 5 dB and 7 dB respectively, to achieve the same BER.

5.4. Multi-code Multi Carrier IDMA system

The PICF MUD is also evaluated in the multi-code multi carrier transmission system in the Rayleigh fading channel. The codes used in the codeset are Maximal length, Gold Code, Walsh-Hadamard and Kasami codes. The following parameters are used in the simulation: number of users=5, number of sub carrier: 16, Data length=256 bits/user, BPSK modulation. Fig.6 shows that the BER performance of MC-MC-IDMA is better than MC-IDMA and MC-MC-IDMA. i.e at $E_b/N_o = 10$ dB, MC-IDMA achieves BER performance of 10^{-3} , whereas in MC-

MC-IDMA system, BER performance of 10^{-4} is achieved in 9 dB itself.

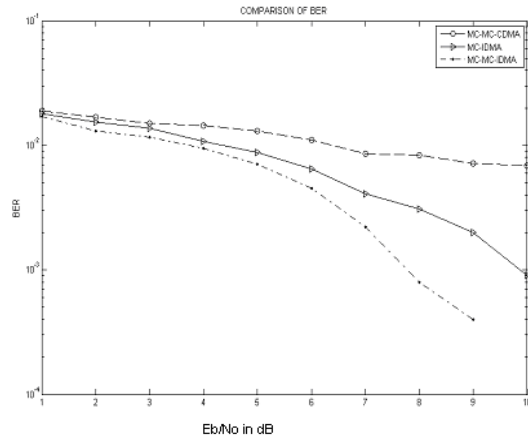

Figure 6. Performance evaluation of MC-MC-CDMA, MC-IDMA and MC-MC-IDMA system using PICF MUD

5.5. OFDM-SDMA System

The uplink of an OFDM-SDMA system is considered with L users and a base station (BS). Each user transmits with a single antenna and BS has multiple receive antennas. It is assumed that the number of simultaneous users is not greater than the number of BS antennas. The OFDM-SDMA system is simulated with MMSE-PICF-MUD receiver and the BER performance is illustrated in fig. 7.

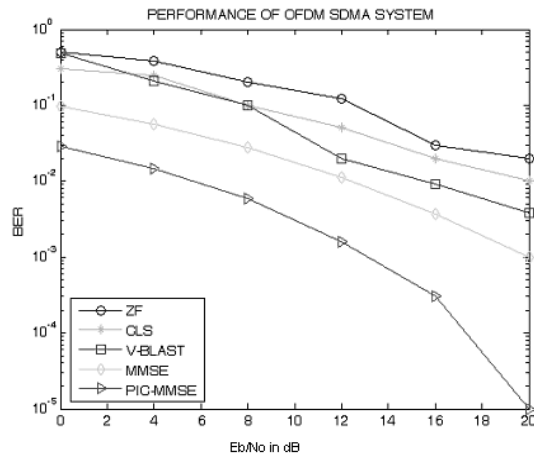

Figure 7. BER Performance of OFDM-SDMA system with different MUD techniques (No. of users=4)

The following parameters are used in the simulation of OFDM-SDMA system: Number of simultaneous users=4, number of antennas=4, Data length=4096 bits/user, QPSK modulation, Carrier frequency=2GHz and the number of sub carrier=64. The BER performance is compared with other multi user detection techniques such as



Zero Forcing, Constrained Least Square (CLS) detector [16], V-BLAST [11] and MMSE detectors. The simulation results illustrate that the MMSE-PIC with feedback MUD provide better BER performance compared to other detectors.

Fig.8 shows the BER performance of the QPSK modulated OFDM-SDMA system for number of antennas with 64 sub carrier for data length of 4096 bits per user. MMSE-PICF MUD is employed at the receiver side.

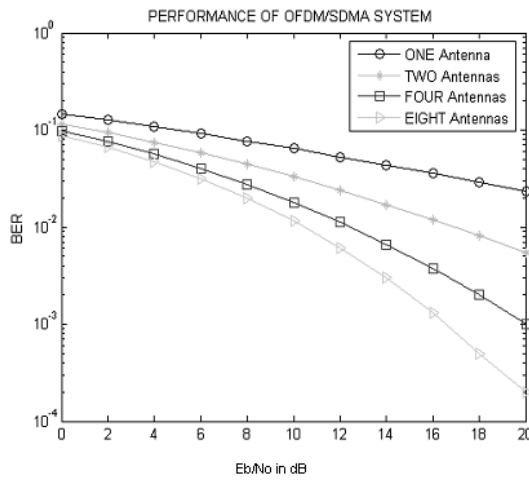

Figure 8. BER performance of OFDM-SDMA system with number of antennas (No. of users=4)

From this graph it is observed that BER is considerably reduced with increasing number of antennas. At $E_b/N_0=20$ dB, the BER performance achieved by different multi user detectors ZF, CLS, V-BLAST, MMSE and MMSE-PICF are 0.02, 0.01, 0.0038, 0.0010 and 0.00001 respectively.

6. CONCLUSIONS

The performance of the proposed multi user detector known as Parallel Interference Cancellation with feedback (PICF MUD) is evaluated in DS-CDMA, SC-IDMA, MC-IDMA, MC-MC-IDMA and OFDM-SDMA systems. From the simulation results it is concluded that PIC with feedback and MMSE-PIC with feedback are found to be suitable multi user detectors for MC-MC-IDMA and OFDM-SDMA multiple access wireless communications.

REFERENCES

- [1] D.R.Brown, M.Motani, V.V.Veeravalli, H.V.Poor, and C.R.Johnson, "On the performance of linear parallel interference cancellation," *IEEE Trans. Inform. Theory*, vol. 47, no. 5, pp. 1957-1970, July 2001.
- [2] Feng X, Tsimenidis C.C., Hinton O.R, Sharif B.S, "Non-linear Multistage multiple Access interference Cancellation receiver for asynchronous DS/CDMA communication systems," *IEEE Vehicular Technology Conference*, vol.2, pp.1114-1118, October 2003.
- [3] Jae-Hong Kim, Jae-Yoon Jeong, Soon-Jin Yeom, Byung-Goo Choi, Yong-Wan Park, "Performance analysis of the hybrid interference canceller for multiple access interference cancellation," *TENCON 99, Proceedings of the IEEE Region 10 Conference*, vol.2, pp.1236-1239, December 1999.
- [4] S.Moshavi, "Multi-User Detection for DS CDMA communications," *IEEE Commun. Magazine*, vol.34, no.10, pp.124-136, October 1996.
- [5] E.Chong, J.Zhang, and D.Tse, "Output MAI distribution of linear MMSE multi user receivers in DS-CDMA systems," *IEEE Trans. Information Theory*, vol. 47, no.3, pp.1128-1144, March 2001.
- [6] Li Ping, LhaiLiu, K.Y.Wu, and W.K.Leung, "Interleave-Division Multiple - Access," *IEEE Trans. Wireless Commun.*, vol.5, no.4, pp. 938 947, April 2006.
- [7] Rong Zhang and Lajos Hanzo, "Iteratively Detected Multi-Carrier Interleave Division Multiple Access," *Microcoll 07*, May 2007.
- [8] Y.W.Cao, C.C.Co, T.T.Tjhung, "A new multi code/multi-carrier DS-CDMA system," *IEEE Global Telecommun.Conference*, vol.1, pp.543-546, November 2001.
- [9] Habib ur Rehman, Imran Zaha, Muhammaad Naeem, Syad Ismail Shah and Jamil Ahmad, "Multicode Multicarrier Interleave Division Multiple Access Communication," *IEEE Multitopic Conference*, pp. 37-41, December 2006.
- [10] Theodore S.Rappaport, "Wireless communication Principles and Practice," Prentice Hall PTR, New Jersey, 1996.
- [11] G.D.Golden, C.J.Foschini, R.A.Valenzuela, and P.W.Wolniansky, "Detection algorithm and initial laboratory results using V-BLAST space-time communication architecture," *Electronics Lett.*, vol.35, pp. 14-16, January 1999.
- [12] Yue Wu, Tao Cui, and Chintha Tellambura, "Optimal Low Complexity Detection for Space Division Multiple Access Wireless



- Systems,” *IEEE Communication Letters*, vol.10, no.3,pp156-158, March 2006.
- [13] P.Vandenameele, L.VanderPerre, G.E.Engels, B.Gyselinckx, and H.J.De Man, “A combined OFDM/SDM Approach,” *IEEE Journal Selected Areas Commun.*, vol. 18, no. 11, pp.2312-2321, November 2000.
- [14] M.Y.Alias, A.K.Samingan, S.Chen, and L.Hanzo, “Multiple antenna aided OFDM employing minimum bit error rate multiuser detection,” *Electronics Letter*, vol. 39, no. 24, pp. 1769-1770, Nov.2003.
- [15] Matthias Munster and Lajos Hanzo, “Performance of SDMA Multi-User Detection Techniques for Walsh-Hadamard-Spread OFDM Schemes,” *IEEE Vehicular Technology Conference*, vol.4, pp.2319-2323, October 2001.
- [16] S.Thoen, L.Deneire, VanderPerre, M.Engels, H.De.Man, “Constraint Least Square detector for OFDM/SDMA – based wireless networks,” *IEEE Trans.on Wireless Commun.*, vol.2 ,no.1, pp.129-140, January 2003.
- [17] Dongxu Shen, Zhengang Pan, Kai-Kit Wong, Victor O.K.Li, “Effective Throughput: A Unified Benchmark for Pilot-Aided OFDM/SDMA Wireless Communication Systems,” *IEEE INFOCOM03*, vol.3, pp.1603-1613, April 2003.