



MODELING AND SIMULATION FOR VOLTAGE SAGS/SWELLS MITIGATION USING DYNAMIC VOLTAGE RESTORER (DVR)

¹ROS LI OMAR, ²NASRUDIN ABD RAHIM, ³MARIZAN SULAIMAN

¹Rosli Omar., Faculty Of Electrical, UTeM, Malacca, Malaysia

²Prof ., Department Of Electrical Engineering Faculty Of Engineering, University Of Malaya, Kuala Lumpur, Malaysia

³Prof., Faculty Of Electrical, UTeM, Malacca, Malaysia

E-mail: omarrosli@yahoo.com

ABSTRACT

This paper describes the problem of voltage sags and swells and its severe impact on non linear loads or sensitive loads. The dynamic voltage restorer (DVR) has become popular as a cost effective solution for the protection of sensitive loads from voltage sags and swells. The control of the compensation voltages in DVR based on dqo algorithm is discussed. It first analyzes the power circuit of a DVR system in order to come up with appropriate control limitations and control targets for the compensation voltage control. The proposed control scheme is simple to design. Simulation results carried out by Matlab/Simulink verify the performance of the proposed method.

Keywords- *Dynamic Voltage Restorer (DVR), voltage sags, voltage swells, sensitive load*

1. INTRODUCTION

Power Quality problems encompass a wide range of disturbances such as voltage sags/swells, flicker, harmonics distortion, impulse transient, and interruptions [1].

Voltage sags can occur at any instant of time, with amplitudes ranging from 10 – 90% and a duration lasting for half a cycle to one minute [3]. Voltage swell, on the other hand, is defined as a *swell* is defined as an increase in rms voltage or current at the power frequency for durations from 0.5 cycles to 1 min. typical magnitudes are between 1.1 and 1.8 up. Swell magnitude is also is also described by its remaining voltage, in this case, always greater than 1.0. [2,3,4].

Voltage swells are not as important as voltage sags because they are less common in distribution systems. Voltage sag and swell can cause sensitive equipment (such as found in semiconductor or chemical plants) to fail, or shutdown, as well as create a large current unbalance that could blow fuses or trip breakers. These effects can be very expensive for the customer, ranging from minor quality variations

to production downtime and equipment damage [5-7].

There are many different methods to mitigate voltage sags and swells, but the use of a custom Power device is considered to be the most efficient method. Switching off a large inductive load or

Energizing a large capacitor bank is a typical system event that causes swells [1].

This paper introduces Dynamic Voltage Restorer and its operating principle. Then, a simple control based on dqo method is used to compensate voltage sags/swell. At the end, MATLAB/SIMULINK model based simulated results were presented to validate the effectiveness of the proposed control method of DVR.

2. CONVENTIONAL SYSTEM CONFIGURATION OF DVR

Dynamic Voltage Restorer is a series connected device designed to maintain a constant RMS voltage value across a sensitive load. The DVR considered consists of:

- a. an injection / series transformer
- b. a harmonic filter,
- c. a Voltage Source Converter (VSC),

- d. an energy storage and
- e. a control system , as shown in Figure 1

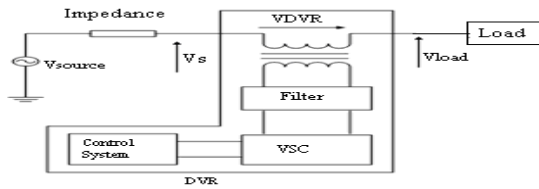

Figure 1: Schematic diagram of DVR

The main function of a DVR is the protection of sensitive loads from voltage sags/swells coming from the network. Therefore as shown in Figure 1, the DVR is located on approach of sensitive loads. If a fault occurs on other lines, DVR inserts series voltage V_{DVR} and compesates load voltage to pre fault value. The momentary amplitudes of the three injected phase voltages are controlled such as to eliminate any detrimental effects of a bus fault to the load voltage V_L . This means that any differential voltages caused by transient disturbances in the ac feeder will be compensated by an equivalent voltage generated by the converter and injected on the medium voltage level through the booster transformer.

The DVR works independently of the type of fault or any event that happens in the system, provided that the whole system remains connected to the supply grid, i.e. the line breaker does not trip. For most practical cases, a more economical design can be achieved by only compensating the positive and negative sequence components of the voltage disturbance seen at the input of the DVR. This option is Reasonable because for a typical distribution bus configuration, the zero sequence part of a disturbance will not pass through the step down transformer because of infinite impedance for this component.

The DVR has two modes of operation which are: standby mode and boost mode. In standby mode ($V_{DVR}=0$), the booster transformer's low voltage winding is shorted through the converter. No switching of semiconductors occurs in this mode of operation, because the individual converter legs are triggered such as to establish a short-circuit path for the transformer connection. Therefore, only the comparatively low conduction losses of the semiconductors in this current loop contribute to the losses. The DVR will be most of the time in this mode. In boost mode ($V_{DVR}>0$),

the DVR is injecting a compensation voltage through the booster transformer due to a detection of a supply voltage disturbance [4].

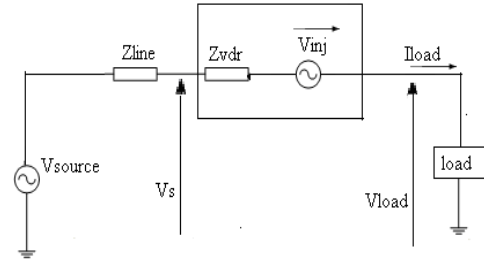

Figure 2: Equivalent Circuit of DVR

Figure 2 shows the equivalent circuit of the DVR, when the source voltage is drop or increase, the DVR injects a series voltage V_{inj} through the injection transformer so that the desired load voltage magnitude V_L can be maintained. The series injected voltage of the DVR can be written as

$$V_{inj} = V_{load} + V_s \tag{1}$$

Where;

V_{Load} is the desired load voltage magnitude
 V_s is the source voltage during sags/swells condition

The load current I_{Load} is given by,

$$I_{load} = \left(\frac{(P_{Load} \pm J * Q_{Load})}{V_{Load}} \right) \tag{2}$$

3. PROPOSED METHOD

A. Main Circuit

Figure 3 shows the configuration of the proposed DVR design using MATLAB/SIMULINK, where the outputs of a three-phase half-bridge inverter are connected to the utility supply via wye-open connected series transformer.

Once a voltage disturbance occurs, with the aid of dqo transformation based control scheme, the inverter output can be steered in phase with the incoming ac source while the load is maintained constant. As for the filtering scheme of the proposed method, output of inverter is installed with capacitors and inductors.

B. Control Algorithm

The basic functions of a controller in a DVR are the detection of voltage sag/swell events in the system; computation of the correcting voltage, generation of trigger pulses to the sinusoidal PWM based DC-AC inverter, correction of any anomalies in the series voltage injection and termination of the trigger pulses when the event has passed. The controller may also be used to shift the DC-AC inverter into rectifier mode to charge the capacitors in the DC energy link in the absence of voltage sags/swells.

The dqo transformation or Park’s transformation [8-10] is used to control of DVR.

The dqo method gives the sag depth and phase shift information with start and end times. The quantities are expressed as the instantaneous space vectors. Firstly convert the voltage from a-b-c reference frame to d-q-o reference. For simplicity zero phase sequence components is ignored.

Figure 4 illustrates a flow chart of the feed forward dqo transformation for voltage sags/swells detection. The detection is carried out in each of the three phases.

The control scheme for the proposed system is based on the comparison of a voltage reference and the measured terminal voltage (Va,Vb,Vc).The voltage sags is detected when the supply drops below 90% of the reference value whereas voltage swells is detected when supply voltage increases up to 25% of the reference value. The error signal is used as a modulation signal that allows to generate a commutation pattern for the power switches (IGBT’s) constituting the voltage source converter. The commutation pattern is generated by means of the sinusoidal pulse width modulation technique (SPWM); voltages are controlled through the modulation.

The block diagram of the phase locked loop (PLL) is illustrated in Figure 4. The PLL circuit is used to generate a unit sinusoidal wave in phase with mains voltage.

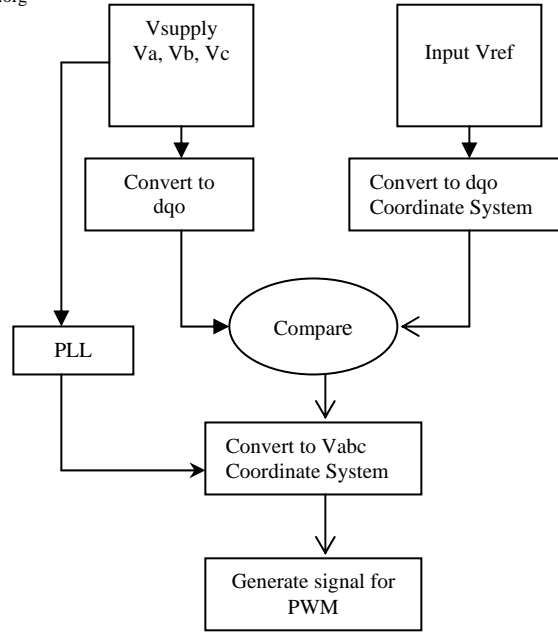

Figure 4 : Flow chart of feed forward control technique for DVR based on dqo transformation

$$\begin{bmatrix} V_d \\ V_q \\ V_o \end{bmatrix} = \begin{bmatrix} \cos(\theta) & \cos\left(\theta - \frac{2\pi}{3}\right) & 1 \\ -\sin(\theta) & -\sin\left(\theta - \frac{2\pi}{3}\right) & 1 \\ \frac{1}{2} & \frac{1}{2} & \frac{1}{2} \end{bmatrix} \begin{bmatrix} V_a \\ V_b \\ V_c \end{bmatrix}$$

(3)

Equation (3) defines the transformation from three phase system a, b, c to dqo stationary frame. In this transformation, phase A is aligned to the d-axis that is in quadrature with the q-axis. The theta (θ) is defined by the angle between phase A to the d-axis.

4. SIMULATION RESULTS AND DISCUSSION

TABLE I: SYSTEM PARAMETERS AND CONSTANT VALUES

Main Supply Voltage per phase	200V
Line Impedance	Ls =0.5mH Rs = 0.1 Ω
Series transformer turns ratio	1:1
DC Bus Voltage	100V
Filter Inductance	1mH
Filter capacitance	1uF

Load resistance	40Ω
Load inductance	60mH
Line Frequency	50Hz

A detailed system as shown in Figure 3 has been modeled by **MATLAB/SIMULINK** to study the efficiency of suggested control strategy. The system parameters and constant value are listed in Table I. It is assumed that the voltage magnitude of the load bus is maintained at 1 pu during the voltage sags/swells condition. The results of the most important simulations are represented in Figures 5-8. The load has been assumed linear with power factor $pf = 0.85$ lagging and its capacity of 5 KVA.

4.1 Voltage Sags

The first simulation shows of three phase voltage sag is simulated. The simulation started with the supply voltage 50% sagging as shown in Figure 5 (a). In Figure 5 (a) also shows a 50% voltage sag initiated at 0.15s and it is kept until 0.35s, with total voltage sag duration of 0.2s. Figures 5 (b) and (c) show the voltage injected by the DVR and the corresponding load voltage with compensation. As a result of DVR, the load voltage is kept at 1 pu.

The effectiveness of the DVR under unbalanced conditions is shown in figure 6, in figure 6 also shows the occurrence of 50% single phase voltage sag on a utility grid. Through simulation the supply voltage with one phase voltage dropped down to 50% as shown in Figure 6 (a). The DVR injected voltage and the load voltage are shown in Figures 6 (b) and (c) respectively. Its corresponding load voltages are shown in Figure 6(c) where it is possible to see that the compensation method is keeping the load voltages constant at 1 p.u.

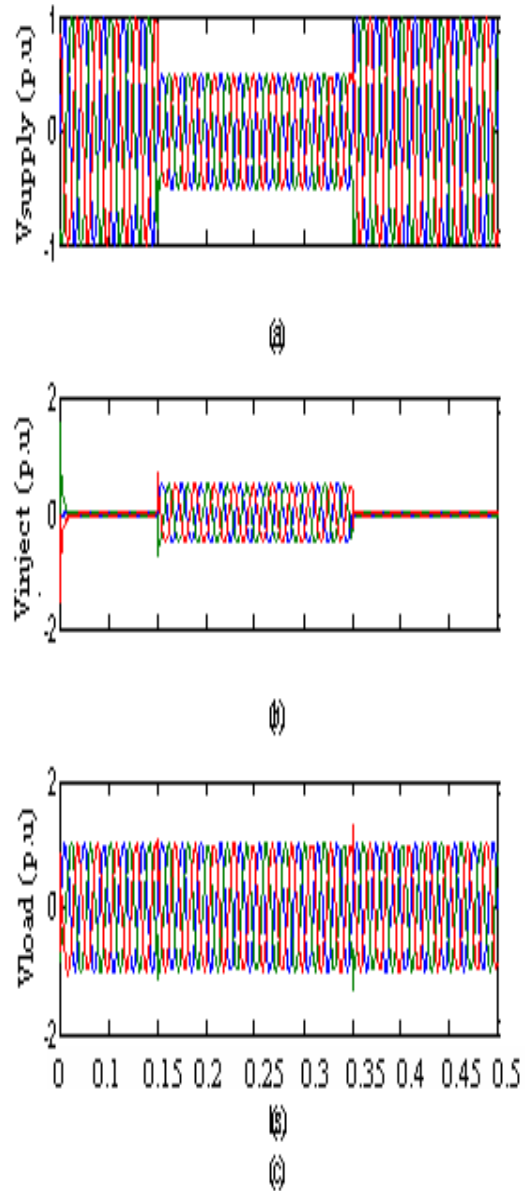

Figure 5 Three-phase voltages sag: (a)-Source voltage, (b)-Injected voltage, (c)-Load

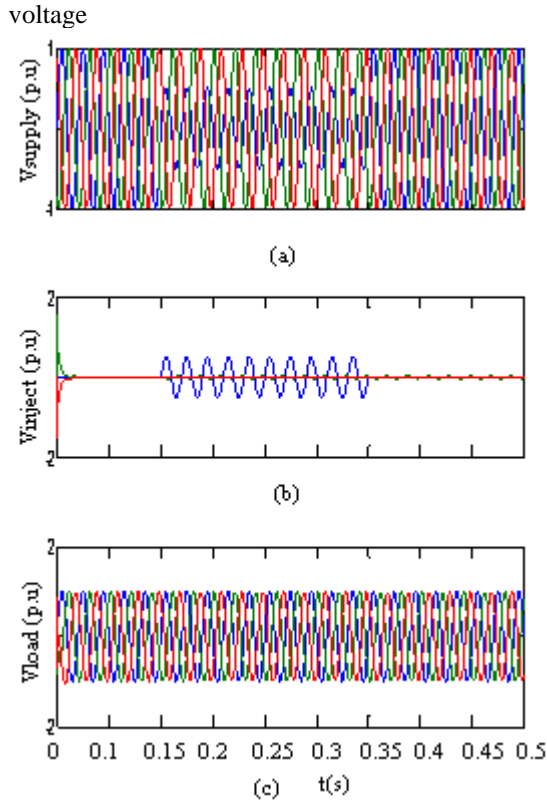

Figure 6 Single-phase voltage sag: (a)-Source voltage, (b)-Injected voltage, (c)-Load voltage

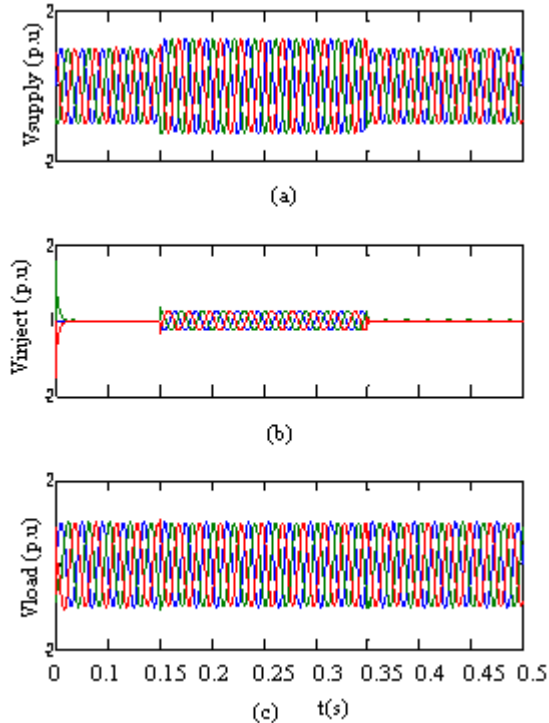

Figure 7 Three-phase voltages swell: (a)-Source voltage, (b)-Injected voltage, (c)-Load voltage

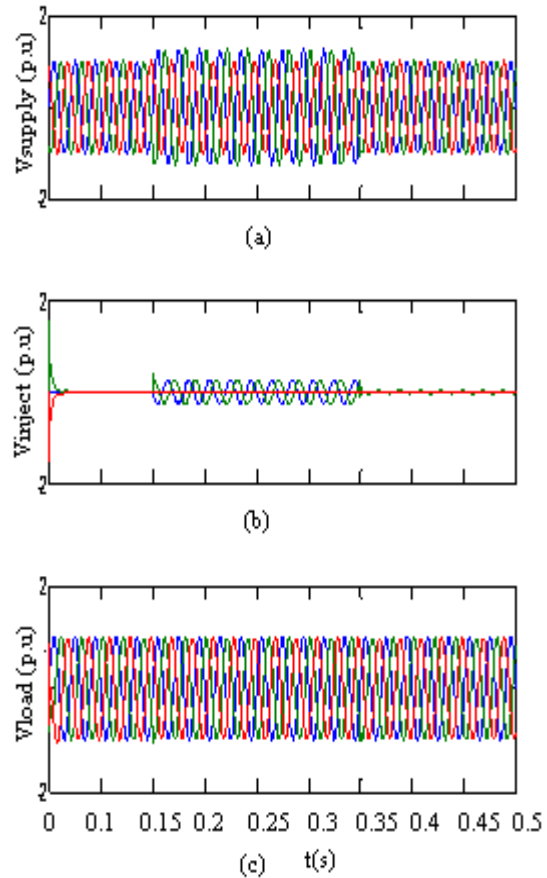

Figure 8 Two-phase voltages swell: (a)-Source voltage, (b)-Injected voltage, (c)-Load voltage

4.2 Voltage Swells

The second simulation shows the DVR performance during a voltage swell condition. The simulation started with the supply voltage swell is generated as shown in Figure 7 (a). As observed from this figure the amplitude of supply voltage is increased about 25% from its nominal voltage. Figures 7(b) and (c) show the injected and the load voltage respectively. As can be seen from the results, the load voltage is kept at the nominal value with the help of the DVR. Similar to the case of voltage sag, the DVR reacts quickly to inject the appropriate voltage component (negative voltage magnitude) to correct the supply voltage. Figure 8 shows that the performance of the DVR with an unbalanced voltage swell. In this case, two of the three phases are higher by 25% than the third phase as shown in Figure 8(a). The injected voltage that is produced by DVR in order to correct the load voltages and the load

voltages maintain at the constant are shown in Figures 8 (b) and (c), respectively.

5. CONCLUSION

The modeling and simulation of a DVR using MATLAB/SIMULINK has been presented. A control system based on dq0 technique which is a scaled error of the between source side of the DVR and its reference for sags/swell correction has been presented. The simulation shows that the DVR performance is satisfactory in mitigating voltage sags/swells.

From simulation results also show that the DVR compensates the sags/swells quickly and provides excellent voltage regulation. The DVR handles both balanced and unbalanced situations without any difficulties and injects the appropriate voltage component to correct rapidly any anomaly in the supply voltage to keep the load voltage balanced and constant at the nominal value.

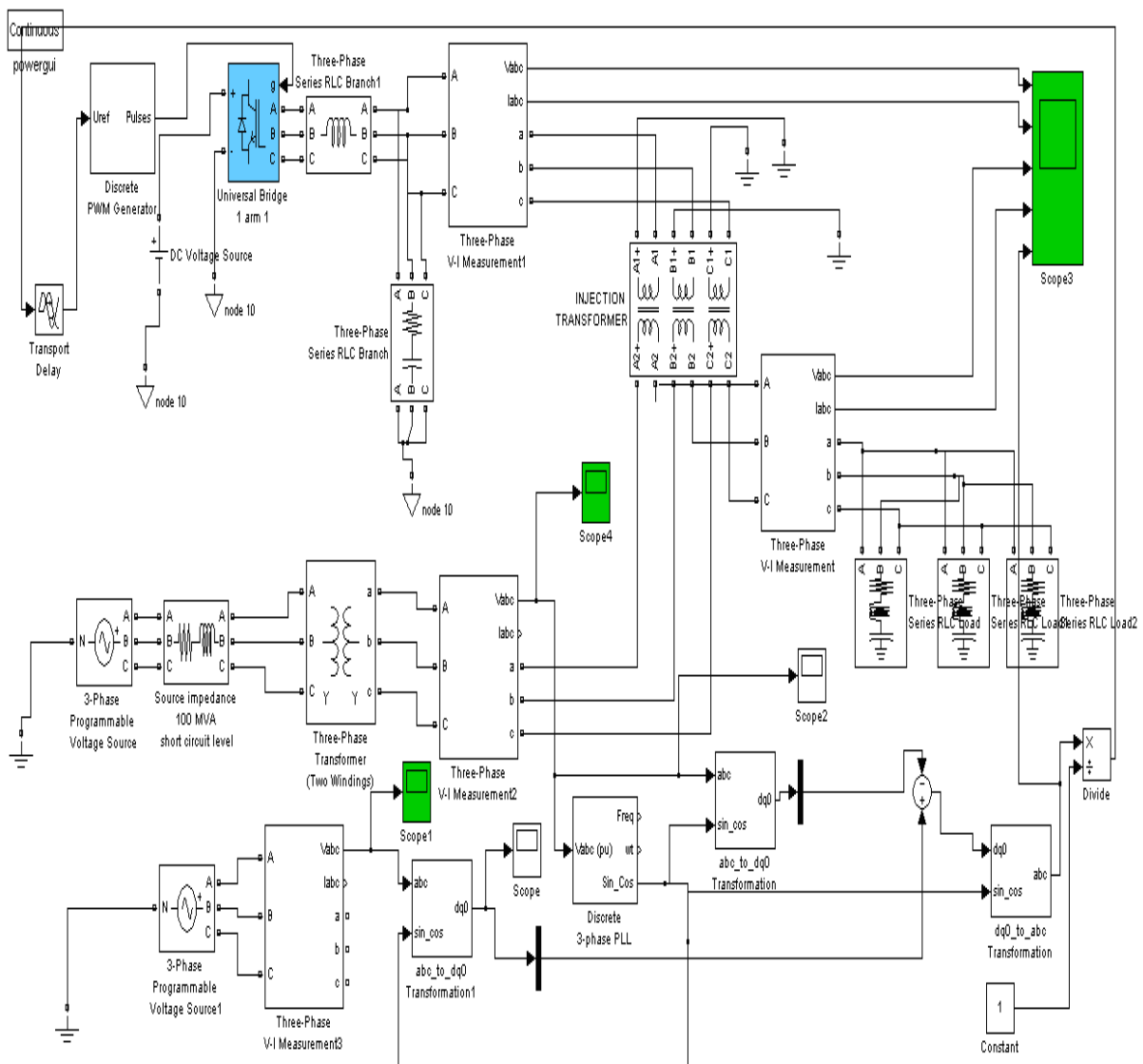

Figure 3: Proposed system configuration



The main advantage of this DVR is low cost and its control is simple. It can mitigate long duration voltage sags/swells efficiently. Future work will include a comparison with a laboratory experiments in order to compare simulation and experimental results.

6. ACKNOWLEDGEMENT

The authors wish to thank UM for providing grant under grant PS002/2007C for this project.

REFERENCES

- [1] N.G. Hingorani, "Introducing Custom Power in IEEE Spectrum," 32p, pp. 41-48, 1995.
- [2] IEEE Std. 1159 – 1995, "Recommended Practice for Monitoring Electric Power Quality".
- [3] P. Boonchiam and N. Mithulananthan, "Understanding of Dynamic Voltage Restorers through MATLAB Simulation," *Thammasat Int. J. Sc. Tech.*, Vol. 11, No. 3, July-Sept 2006.
- [4] J. G. Nielsen, M. Newman, H. Nielsen, and F. Blaabjerg, "Control and testing of a dynamic voltage restorer (DVR) at medium voltage level," *IEEE Trans. Power Electron.*, vol. 19, no. 3, p.806, May 2004.
- [5] A. Ghosh and G. Ledwich, "Power Quality Enhancement Using Custom Power Devices," Kluwer Academic Publishers, 2002.
- [6] S. Chen, G. Joos, L. Lopes, and W. Guo, "A nonlinear control method of dynamic voltage restorers," in 2002 IEEE 33rd Annual Power Electronics Specialists Conference, 2002, pp. 88- 93.
- [7] R. Buxton, "Protection from voltage dips with the dynamic voltage restorer," in IEE Half Day Colloquium on Dynamic Voltage Restorers – Replacing Those Missing Cycles, 1998, pp. 3/1- 3/6.
- [8] H. Awad, J.Svensson, M. Bollen, "Mitigation of Unbalanced Voltage Dips Using Static Series Compensator", *IEEE Trans. On Power Elec.*, Vol. 19, No. 13, May 2004
- [9] B. Singh, A. Adya, J. Gupta, "Power Quality Enhancement with DSTATCOM for small Isolated Alternator feeding Distribution System" *Power Electronics, And Drive System 2005, (PEDS 2005)*, Vol1., 16-18 Jan Pages: 274-279
- [10] C. Hochgraf, R. Lasseter, "Stacom controls for Operation with Unbalanced Voltages " *IEEE Trans. On Power delivery*, Vol. 13, No. 2, April 1998.

BIOGRAPHY

Rosli Omar received the degree in electrical & electronics engineering from University Technology Malaysia in 1991 and M.Eng from University Of Science Malaysia in 2001. Where he is currently working toward the Ph.D, degree in electrical and electronic engineering. His research interests include powr electronic, power quality and renewable energy

Professor Dr. Nasrudin Abdul Rahim received the B.Sc. (Hons.) and M.Sc. degrees from the University of Strathclyde, Glasgow, U.K., and Ph.D, degree in 1995 from Heriot-Watt University, Edinburgh, U.K. He is expertise in Power Electronics and Drives in the Department of Electrical Engineering. Currently, he the Director of the Center for Research Power Electronics, Drives, automation and control Faculty of Engineering. has received a University Excellence Staff Award from the Universiti. His research interests include power electronics and drives, and related industrial applications.

Prof Dr Marizan Sulaiman obtained his B.sc., M.E.E. and Ph.D. in Electrical from University Of Missouri-Columbia (UMC), USA in 1984, 1985 and 1989. Currently he is the Dean of Faculty of Electrical, University Technical Malaysia Malacca. His research interests including all area of power systems, energy efficient systems, control and instrumentation and e-learning.