



HYBRID SEVEN LEVEL H- BRIDGE INVERTER BASED DSTATCOM CONTROL USING SUB-HARMONIC PULSE WIDTH MODULATION TECHNIQUE

¹D.KALYANAKUMAR, ² DR.V.KIRBAKARAN, ³K.RAMASH KUMAR

¹Faculty, Department of Electrical&Electronics Engineering, Saranathan College of Engineering, Trichy, India-620012

²Asst.Professor, Department of Rural Enertgy, Gandhigram University, Gandhigram, Tamilnadu, India

³ Lecturer, Department of Electrical&Electronics Engineering, A.M.S.C.E, Chennai, India-600055

ABSTRACT

This paper presents an investigation of Hybrid Seven-Level (HSL) H – bridge Inverter is used in a Distribution Static Compensator (DSTATCOM) in Power System (PS), making use of HSLI benefits of low harmonics distortion, reduced number of switches to achieve the seven- level inverter output over the conventional cascaded seven level inverter and reduced switching losses. In order to improve the power factor, compensate the reactive power and suppress the total harmonics distortion (THD) drawn from a Non-Liner Diode Rectifier Load (NLDRL) of DSTATCOM, we propose a Sub-Harmonics Pulse Width Modulation (SHPWM) technique is used as control for the switches of HSL H – bridge Inverter. The D-Q reference frame theory is used to generate the reference compensating currents for DSTATCOM and proportional and integral (PI) control is used for capacitors dc voltage regulation for DSTATCOM. A HSL H – bridge Inverter is considered for shunt compensation of a 4.5 kV distribution system. The results are validated through MatLab/Simulink simulation software.

Keywords: *DSTATCOM, Sub-Harmonic Pulse Width Modulation, Proportional-Integral Control, D-Q Reference Frame Theory.*

1. INTRODUCTION

Shunt compensation for medium voltage distribution systems requires higher rating for voltage source converters (VSCs). Ratings of the semiconductor devices in a VSC are always limited; therefore for higher rated converters it is desirable to distribute the stress among the number of devices using multilevel topology [1]. Cascaded multilevel configuration of inverter has the advantage of its simplicity and modularity over the configurations of diode-clamped and flying capacitor multilevel inverters. Application of cascaded multilevel converters for shunt compensation of distribution systems has been described in [2]-[3].

The multilevel power conversion has been receiving increasing attention in the past few years for high power application [4]. Numerous topologies have been introduced and studied extensively for utility and drive applications in the recent literature. These converters are suitable in high voltage and high power applications due to their ability to synthesize waveforms with better harmonic spectrum and attain higher voltage with a

limited maximum device rating [1], [4]. There are various current control methods for two-level converters [5]. Hysteresis control of power converters, based on instantaneous current errors, is widely used for the compensation of the distribution system as it has good dynamic characteristics and robustness against parameter variations and load non-linearities [6].

A DSTATCOM is a voltage source converter (VSC) based device. When operated in a current control mode, it can improve the quality of power by mitigating poor load power factor, eliminating harmonic content of load and balancing source currents for unbalanced loads [6]-[7].

Therefore in this paper HSL H – bridge Inverter based DSTATCOM control in PS is proposed. A SHPWM technique is used as control for DSTATCOM. The HSL H – bridge Inverter topology based DSTATCOM balances the source currents and reduces THD while improving the load power factor. The simulation of DSTATCOM with its control model is implemented in MatLab/Simulink.

In section 2, we will present the operation of HSL H – bridge Inverter. The control of

DSTATCOM is presented in section 3. A SHPWM technique is well executed in section 4. Simulation results of system are discussed in section 5. The conclusions and future work of system is discussed in section 6.

2. OPERATION OF HYBRID SEVEN-LEVEL H-BRIDGE INVERTER

Normally, the voltage blocking capability of high speed devices such as Insulated Gate Bipolar Transistors (IGBT) and the switching speed of high voltage device like Integrated Gate Commutated Thyristors (IGCT) is found to be limited [8]. With a modular H- bridge topology [8], realization of multilevel inverters using a hybrid approach involving IGBTs and IGCTs operating in synergism is possible.

Hybrid multilevel inverter topologies have been studied for high power applications in [9] – [10]. The topology presented in reference [10] combines a Gate Turn-Off (GTO) thyristor based inverter and an IGBT inverter, similar to that shown in Fig. 1. It may be verified that with a combination of 3 kV and 1.5 kV dc bus voltages in this topology, it is possible to synthesize stepped waveforms with seven voltage levels viz -3.5 kV, -3 kV, -1.5 kV, 0, 1.5 kV, 3 kV, 4.5 kV at the each phase leg output. As shown in Fig. 1, the higher voltage levels ($\pm 3kV$) are synthesized using GTO inverters while lower voltage levels ($\pm 1.5kV$) are synthesized using IGBT inverters. But it is well known that switching capability of GTO thyristors is limited at high frequencies [9]. Hence a hybrid modulation strategy, which incorporates stepped synthesis in conjunction with variable pulse width of the consecutive steps, is proposed. The switching state of the inverters for various levels of command signal is listed in Table I.

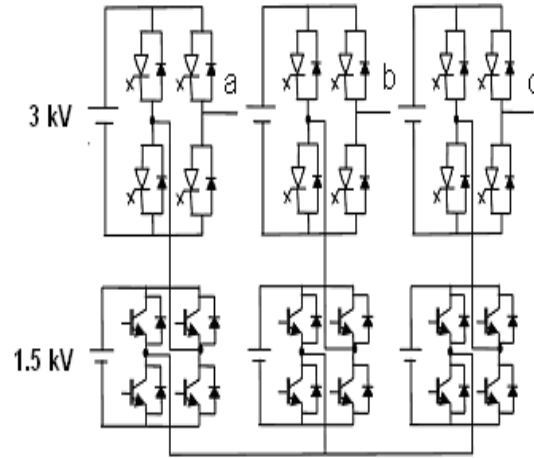

Fig. 1. Simplified schematic of the Hybrid Seven Level H-Bridge Inverter.

TABLE I
Switching Between a and b

Command Signal (Desired Output)	GTO Inverter	IGBT Inverter
Between -4.5 and -3.0 kV	-3.0 kV	0 ↔ -1.5 kV
Between -3 and -1.5 kV	-3.0 kV	0 ↔ 1.5 kV
Between -1.5 and -0.0 kV	0.0 kV	0 ↔ -1.5 kV
Between 0.0 and 1.5 kV	0.0 kV	0 ↔ 1.5 kV
Between 1.5 and 3 kV	3 kV	0 ↔ -1.5 kV
Between 3 and 4.5 kV	3 kV	0 ↔ 1.5 kV

3. DSTATCOM CONTROL

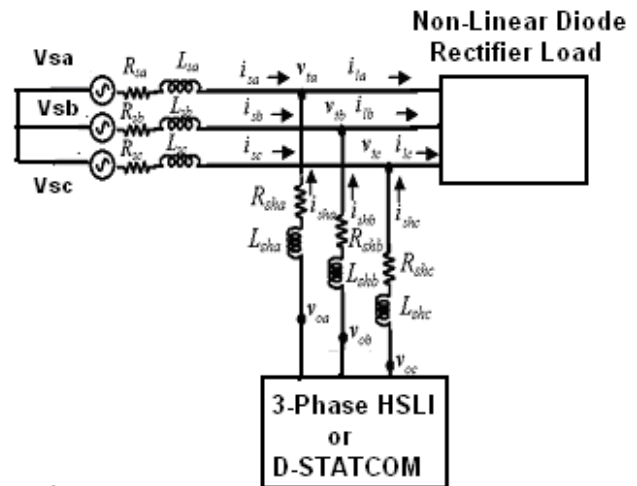

Fig. 2. Shunt compensation of three-phase DSTATCOM in PS.

Fig. 2 shows a three-phase four-wire distribution system that is compensated by a DSTATCOM in PS. The three-phase load is

supplied from the voltage source V_{sk} through the feeder with the impedance of (R_{sk}, L_{sk}) , where $k = a, b, c$ for the three-phase respectively. The DSTATCOM is represented by VSCs in the shunt path with the interfacing inductance L_{shk} . The resistance R_{shk} represents the loss equivalent due to the inverter switching. The voltage at the Point of Common Coupling (PCC) is denoted by V_{tk} . The currents flowing through the different branches at the PCC are the source current I_{sk} , the load current i_{lk} and the current injected in shunt branch I_{skk} .

A. Reference Currents Generation

There are several methods to extract the harmonic components from the detected three-phase waveforms [7]. Among them, the so-called $p - q$ theory based on time domain has been widely applied to the harmonic extraction circuit of active filters. The detected three-phase voltage is transformed into the $D - Q$ coordinates as shown in Fig. 3. The second order digital high pass filters (HPFs) with the same cut off frequency as 20Hz extract the dc component V_{hd}^* , V_{hq}^* and V_0 which corresponds to the fundamental frequency in the coordinates.

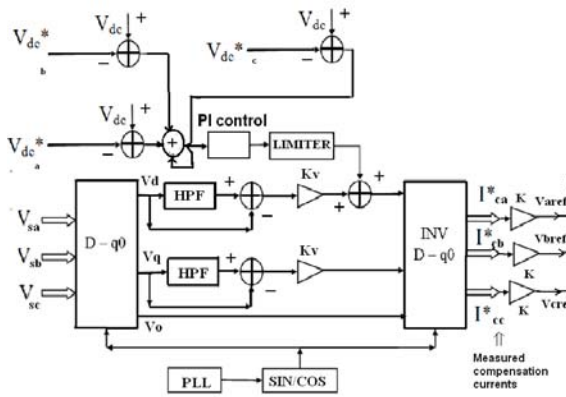

Fig.3. Block diagram of the control circuit equipped with the function of voltage regulation and harmonic damping or reduction.

In line – voltage regulation part is performed by a feedback control. Two co – ordinates V_d and V_q is compared with harmonic extracted voltage V_{hd}^* and V_{hq}^* . A gain K_v amplifies and to produce current references for harmonic damping I_{hd} , I_{hq} , and I_0 as shown in equation (1), equation (2) and equation (3). The current reference for the voltage – source inverter is the sum of the current references from the three parts, as follows:

$$I_{cd}^*(s) = K_v (G_h V_{hd}^* - V_d) + (V_{dc}^* - V_{dc}) \quad (1)$$

$$I_{cq}^*(s) = K_v (G_h V_{hq}^* - V_q) \quad (2)$$

$$I_0^*(s) = 1/3 (V_{sa} + V_{sb} + V_{sc}) \quad (3)$$

The obtained current reference is converted to three phase current reference by inverse $D - Q$ transformation I_{ca}^* , I_{cb}^* , and I_{cc}^* . The three-phase reference compensating current is compared with the DSTATCOM compensating current extracted from ac system. Thus three phase compensating current I_{ca} , I_{cb} , and I_{cc} are produced.

Each phase of the compensating currents is amplified by a gain K in order to produce the three AC voltage references of the feedback loop, given by:

$$V_{aref} = K * (I_{ca}^* - I_{mca}) \quad (4)$$

$$V_{bref} = K * (I_{cb}^* - I_{mcb}) \quad (5)$$

$$V_{cref} = K * (I_{cc}^* - I_{mcc}) \quad (6)$$

Finally, each voltage reference of the DSTATCOM is compared with a multicarrier triangular waveform (1000 Hz) to generate the switching patterns for the HSL H – bridge Inverter.

B. DC Bus Voltage Control

A DC bus controller is required to regulate the DC bus voltage V_{dc} and to compensate the inverter losses in Fig. 3. The measured DC bus voltage V_{dc} of each phase is compared with its reference value V_{dc}^* . Similarly, the remaining phases and added all the error signals. The resulting error is applied to a PI regulator. The proportional and integral gains are set to $0.4 \Omega^{-1}$ and $2 \Omega^{-1} s^{-1}$ respectively [11]. Moreover, the DSTATCOM can build up and regulate the DC capacitor voltage, the electrical quantity to be controlled in the dc-voltage feedback loop is $(V_{dc}^* - V_{dc})$.

C. Sub-Harmonics Pulse Width Modulation (SHPWM) technique

Conventional SHPWM technique for multilevel inverters employ extension of carrier based techniques for two level inverters. It has been reported that the spectral performance of a five level waveforms can be significantly improved by employing alternative dispositions and phase shift in the carrier signals [12]-[13]. This paper extends this concept to a seven level case where the available options for polarity and phase variation. The carrier polarity variation is implemented control for DSTATCOM in this paper. It is based



on a comparative evaluation of possible dispositions of triangular carrier waveforms depending on their relative polarities. For an m -level inverter this technique requires $m-1$, which are compared to a reference sine wave. Thus, for a seven-level inverter the number of carrier signals is six and there exists five possible carrier signal configurations. The carriers are named +3V, +2V, +1V, -1, -2V and -3V after their dc position. Their phase position is + for a carrier in phase and - for a carrier 180 degree out of phase as shown in Fig.5.

4. SIMULATION RESULTS

The main purpose of this section presents the simulation results of DSTATCOM in PS. Simulations have been performed on the DSTATCOM in PS with parameters listed in Table II. The performance of system is evaluated in MatLab/Simulink.

TABLE II
Parameters of DSTATCOM

Parameters name	Numerical Value
Source voltage Vsk	4.5 kV , 50 Hz (line r.m.s)
DC Capacitors	5000 uF
D.C capacitor reference voltage (each phase)	4.5 kV
switching frequency	1kHz
Diode rectifier Non- linear Load resistance and inductance	20Ω , 0.1 mH
Shunt inductance and resistance	2mH, 0.1 ohms
Source resistance and inductance	1mH, 0.1 ohms

The THD in the source current for uncompensated system is 10.5%. The three-phase currents are unbalanced with the poor power factor. Fig. 4 shows the source currents for the uncompensated system. It is desired to bring down the THD in source current to be within an acceptable limit with good tracking of fundamental component while balancing the three-phase source currents. Fig. 5 shows generation of reference and carriers signal for SHPWM technique, which is used to control the switches of HSL H- bridges inverter.

Fig. 6 shows the compensated source currents using the proposed modulation and control. The source currents are balanced with the THD improved to 4.23% as shown in Fig. 7.

Fig. 8 shows the load currents for the compensated system. It can be observed that, which is an acceptable limit. The shunt current tracking

characteristic is shown in Fig. 9. In an error of about 25 A (rms) is observed in the tracking of the fundamental component.

The 7-level inverter output voltage for the phases- a, b and c is shown in Fig. 10. Fig. 11 shows the seven level inverter output voltage for a-phase. An average switching frequency of 1000 Hz is observed for all the switches. The source current is in phase with the terminal source voltage as shown in the Fig. 12 (for phase-a only). This implies a near unity power factor operation.

Fig. 13 shows the convergence of the dc-link voltage of the cascaded HSL H – bridges Inverter for the phase-a. It can be found that the dc voltage has small ripple with designed PI control.

5. CONCLUSIONS

This paper studied a HSL H – bridge Inverter is used in a DSTATCOM in PS has been successfully demonstrated in MatLab/Simulink. The benefits of HSL H – bridge Inverter has low harmonics distortion, reduced number of switches to achieve the seven- level inverter output over the cascaded seven level inverter and reduced switching losses.

The HSL H – bridge Inverter for installation on a power distribution system, with focus on harmonic reduction and voltage regulation performances. HSL – H bridge significantly reduces harmonics present in the distribution system. The results were showed good dc bus voltage – regulation, reduced source harmonic currents and have stable operation. The further work focuses on the study of intelligent control for DSTATCOM.

REFERENCES:

- [1] J. S Lai and F. Z. Peng, "Multilevel converters- A new breed of power converters," *IEEE Trans. Industry Applications*, vol.32, no.3,
- [2] F. Z. Peng., J. W. McKeever and, D .J. Adams, "A power line conditioner using cascade multilevel inverters for distribution system," *IEEE Trans. Industry Applications*, vol.34, no.6, pp. 1293-1298, Nov.-Dec.1998.
- [3] W. Liqiao, L. Ping, L. Jianlin and Z. Zhongchao, "Study on shunt active power filter based on cascaded multilevel converters," 35th



- IEEE Power Electr. Spec. Conf. (APEC)*, vol.5, pp. 3512-3516, 20-25 June 2004.
- [4] B.S.Suh, G. Sinha, M.D. Manjrekar, T.A. Lipo,"Mulilevel Power Conversion- An Overview of Topologies and Modulation Strategies," OPTM'98 Conference Proceedings, pp. AD-11-AD-24, 1998.
- [5] M. P. Kazmierkowski and L. Malesani, "Current control techniques for three-phase voltage-source PWM converters: A survey," *IEEE Trans.Industrial Electronics*, vol.45, no.5, pp. 691-703, Oct. 1998.
- [6] A. Ghosh and G. Ledwich, *Power Quality Enhancement using Custom Power Devices*, Kluwer Academic Publisher, Boston, MA, 2002.
- [7] A. Ghosh and G. Ledwich, "Load Compensating DSTATCOM in weak AC systems," *IEEE Trans. Power Delivery*, vol. 18, No. 4, pp. 1302-1309, Oct. 2003.
- [8] P. K. Steimer, H.E. Gruning, J. Wuninger, E. Caroll, S.Klaka, S. Linder,"A New Emerging Technology for High Power, Low Cost Inverters,"*IEEE-IAS'98 Conference Proceedings*, pp.1592-1599, 1998.
- [9] H. Gruning,"Power Electronics Circuit Arrangement having Plural Power Converters", U.S. Patent No. 5,805,487, 1998.
- [10] M.D. Manjrekar, T.A. Lipo,"A Hybrid Mulilevel Inverters Topology for Drive Applications," *IEEE-APEC'98 Conference Proceedings*, pp. 523-529, 1998.
- [11] D. N. Zmood and D. G. Holmes, "Stationary frame current regulation of PWM inverters with zero steady-state error," *IEEE Trans. Power. Electr.*, vol.18, no.3, pp. 814-822, May 2003
- [12] G. Carrara, S. Gardelta, M. Marchesoni,"A new multilevel PWM method: theoretical analysis", *IEEE Trans. On power electronics* Vol. 7. No. 3 , July, pp.497-505, 1992.
- [13] V. Agelidis, M. Calais," Application specific harmonic performance evaluation of multicarrier PWM techniques", *IEEE-PESC'98 Conference Record*, pp. 172-178, 1998.

AUTHOR PROFILES:

D.Kalyanakumar was born in the year 1952 at Tiruchirapalli. He has completed his Bachelor of Engineering in Electrical & Electronics Engineering and his Post graduation in Energy Engineering from National Institute of

Technology, Tiruchirapalli. The author is also an Accredited Energy Auditor by the Bureau of Energy Efficiency. The author has one international paper and four national papers at his credit. Also presented papers in two National conferences. He has twenty years of industrial experience and twelve years of academic experience in India and abroad. Pursuing Ph.D in the area of Power Quality at Gandhigram Rural University. Presently working as Professor in the Department of Electrical & Electronics Engineering, Saranathan College of Engineering, Tiruchirapalli, Tamilnadu.



Dr. V. Kirubakaran was born in the year 1975 at Tiruchirapalli, Tamilnadu. He has completed his Doctoral degree from National Institute of Technology, Tiruchirapalli. He has done his Ph.D in Bio-mass gasification. He has six

international papers and three national papers at his credit. Presently he is working as Asst. Professor in the Department of Rural Energy, Gandhigram Rural University, Gandhigram, Dindigul District, Tamilnadu.

K. Ramash Kumar was born in Cuddalore, India on October 12, 1979. He received the B.E degree in Electrical and Electronics Engineering from Annai Teresa College of Engineering, Villupuram Dist, India, in 2002, and the M.Tech degree from Pondicherry Engineering College, Pondicherry, India, in 2005. Currently, he is pursuing Ph.D in the field of power electronics at the school of Electrical Engineering Dept., J.N.T.U, Hyderabad, India. His field of interest includes classical controllers design for dc-dc converters, Luo converters, resonant converters, modeling of power converters, active

power filters, high power factor converters, multilevel converters, and Inverters. He is having a teaching experience of 7 years in Engineering Colleges. He has authored more than 7 papers published in international and national conference proceedings and professional journals. Currently, he is working as Lecturer in A.M.S.C.E, Chennai-55, and Tamilnadu, India.

Fig.4. Three phase source currents for uncompensated DSTATCOM in PS

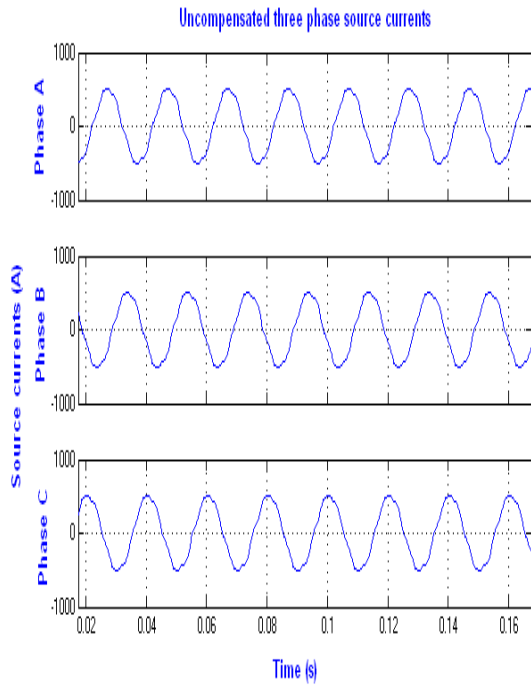

Fig. 6. Three phase source currents for compensated DSTATCOM in PS.

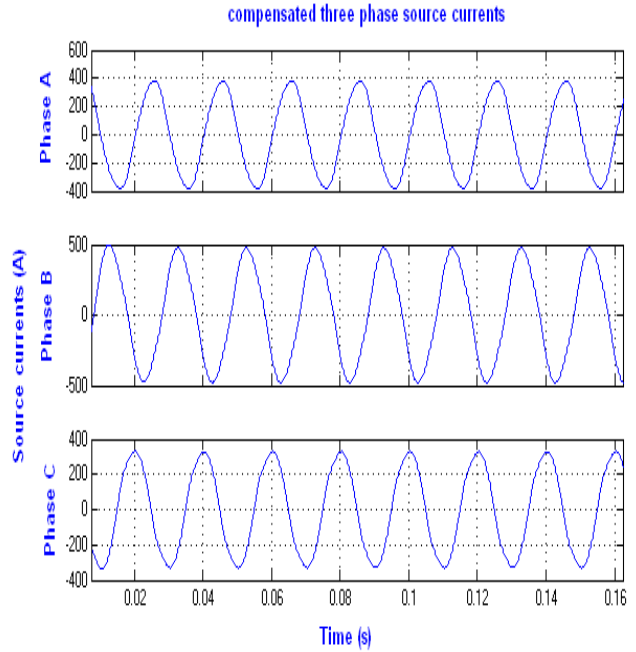

Fig. 5. Reference and carriers signals for SHPWM technique.

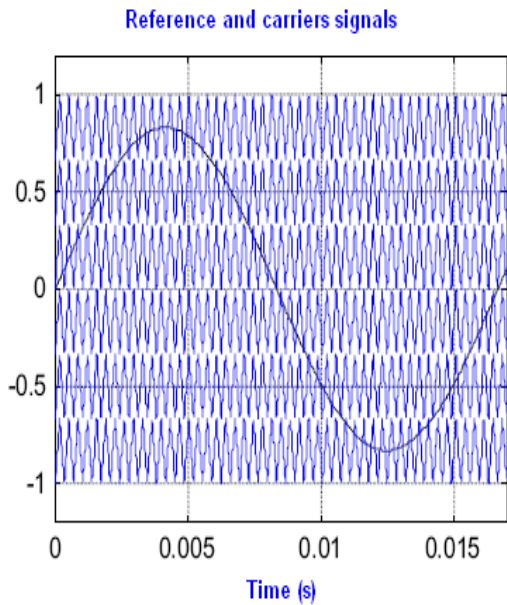

Fig. 7. THD for phase A source currents of compensated DSTATCOM in PS.

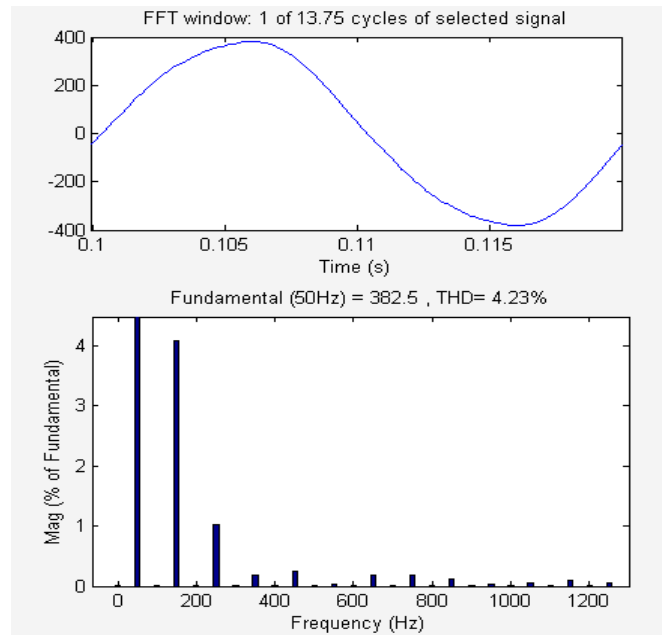



Fig 8. Three phase load currents for compensated DSTATCOM in PS

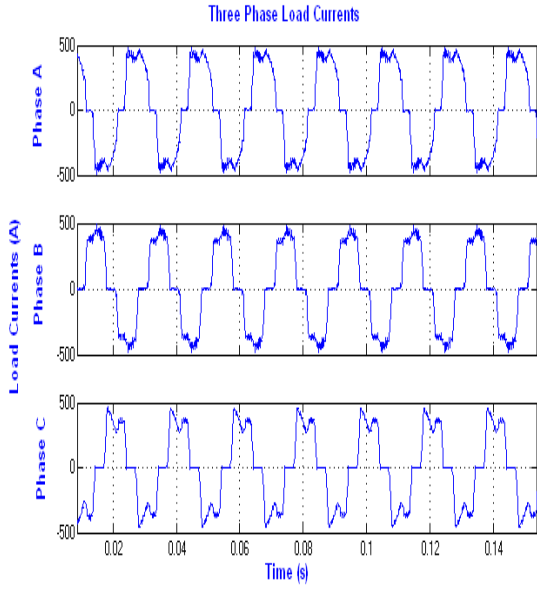

Fig. 10. Inverter output voltage for three phases.

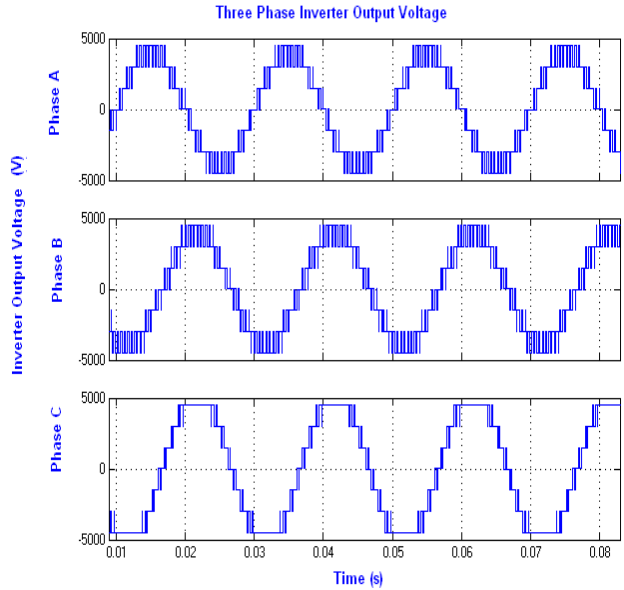

Fig. 9 shows the three phase compensated currents source currents for DSTATCOM.

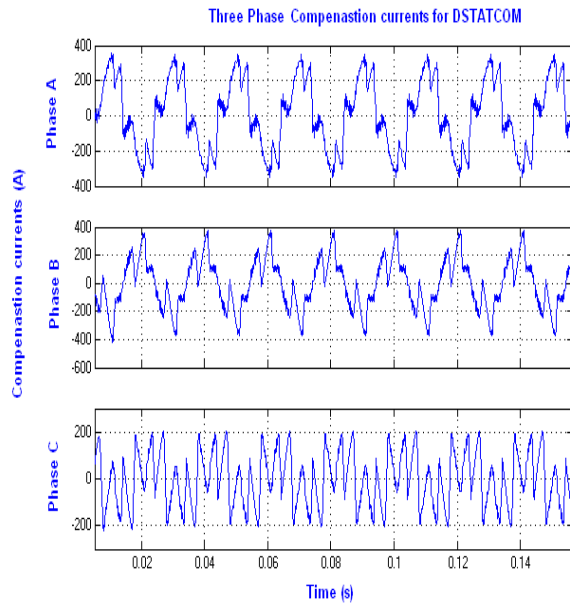

Fig.11. Inverter output voltage for phase - a.

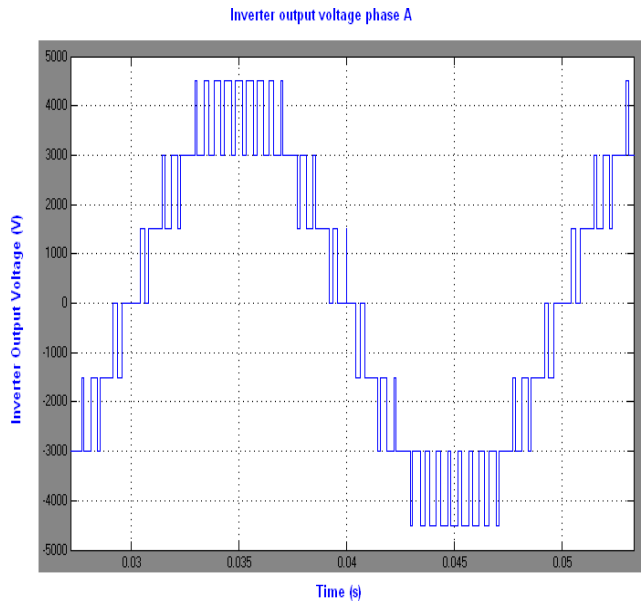

Fig. 12 In-phase source current with terminal voltage for phase-a.

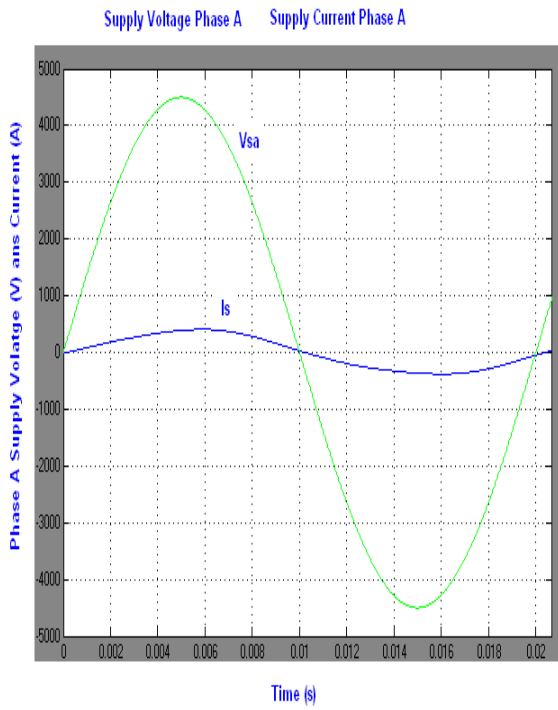

Fig. 13. DC link voltage convergence of the cascaded H-bridges for phase-a.

