

DIVERSITY SCHEMES FOR WIRELESS COMMUNICATION- A SHORT REVIEW

NEELAM SRIVASTAVA

Assistant Professor, Department of Electronics, Institute of Engineering & Technology, Lucknow
Uttar Pradesh, India-226021

ABSTRACT

Now-a-days the requirements of wireless communication are to have high voice quality, high data rates, multimedia features, lightweight communication devices etc. But the wireless communication channel suffers from much impairment. One of them is fading which is due to the effect of multiple propagation paths, and the rapid movement of mobile communication devices. In a typical wireless communication environment, multiple propagation paths often exist from a transmitter to a receiver due to scattering by different objects. Signal copies following different paths can undergo different attenuation, distortions, delays and phase shifts. So, this is necessary to reduce the problem of fading, but not at the cost of extra power or additional bandwidth. One effective solution is proposed for wireless system named diversity, with out the requirement of power or extra bandwidth. This paper discusses about the characteristics of fading channels and a broad classification of various diversity techniques. To overcome the effect of fading various combining techniques are used at the receiver to get good signal at the receiver for improving the overall performance of the communication system. They are explained using very simple mathematics.

Key-Words: *Fading, Diversity, Fading channels, Combining techniques, Wireless Communications, MIMO.*

1. INTRODUCTION

Wireless Communication has made a tremendous impact on the lifestyle of a human being. Wireless Network provides high speed mobility for voice as well as data traffic. The fundamental phenomenon makes which makes transmission unreliable is time varying Fading. The phenomenon is described as the constructive/destructive interference between signals arriving at the same antenna via different paths, and hence with different delays and phases, resulting in random fluctuations of the signal level at the receiver. When destructive interference occurs, the signal power can be significantly reduced and the phenomenon is called as Fading. Deep fades that may occur at particular time or frequency or in space result in severe degradation of the quality of the signal at the receiver making it impossible to decode or detect. Multipath fading arises due to the non-coherent combination of signals arriving at the receiver antenna.

Theoretically, the most effective, the most effective may to mitigate multipath fading in wireless channel is transmitter power control. If channel conditions as experienced by the receiver

on one side of the link are known at the transmitter on the other side, the transmitter can preprocess the signal in order to overcome the effects of the channel. But there are some problems in this method. They are the dynamic range of transmitter and if the uplink and down link frequencies are different then transmitter does not have the knowledge of channel experienced by the transmitter. Hence, the channel information has to be fed back from the receiver to the transmitter. Other effective technique is to provide some form of diversity.

2. FADING CHANNELS

Communication through fading channels can be difficult. Special techniques may be required to achieve satisfactory performance. The general time varying fading channel model is too complex for understanding and performance analysis for wireless channels. One approximate channel model is the wide-sense stationary uncorrelated scattering (WSSUS). In WSSUS model, the time-varying fading process is assumed to be wide-sense stationary random process and the signal copies from the scatterings by different objects are assumed to be independent.[1,4] The following

parameters are often used to characterize a WSSUS channel:

- **Multipath Spread (T_m)** It tells us the maximum delay between paths of significant power in the channel.
- **Coherence Bandwidth $(\Delta f)_c$** Gives an idea of how far apart –in frequency– for signals to undergo different degrees of fading.
- **Coherence Time $(\Delta t)_c$** Gives a measure of the time duration over which the channel impulse
- **Doppler Spread B_d** It gives the maximum range of Doppler shifts.

2.1 Classification of fading channels

Based on the parameters of the channels and the characteristics of the signal to be transmitted, time-varying fading channels can be classified as:

2.1.1 Frequency non-selective versus frequency selective

If the bandwidth of the transmitted signal is small compared with $(\Delta f)_c$, then all frequency components of the signal would roughly undergo the same degree of fading. The channel is then classified as frequency non-selective (also called flat fading). We notice that because of the reciprocal relationship between $(\Delta f)_c$ and $(\Delta t)_c$ and the one between bandwidth and symbol duration, in a frequency non-selective channel, the symbol duration is large compared with $(\Delta t)_c$.

In this case, delays between different paths are relatively small with respect to the symbol duration. We can assume that we would receive only one copy of the signal, whose gain and phase are actually determined by the superposition of all those copies that come within $(\Delta t)_c$.

On the other hand, if the bandwidth of the transmitted signal is large compared with $(\Delta f)_c$, then different frequency components of the signal (that differ by more than $(\Delta f)_c$ would undergo different degrees of fading. The channel is then classified as frequency selective. Due to the reciprocal relationships, the symbol duration is small compared with $(\Delta t)_c$. Delays between different paths can be relatively large with respect to the symbol duration. We then assume that we would receive multiple copies of the signal.[5,6]

2.1.2 Slow fading versus fast fading

If the symbol duration is small compared with $(\Delta t)_c$, then the channel is classified as slow fading.

Slow fading channels are very often modeled as time-invariant channels over a number of symbol intervals. Moreover, the channel parameters, which are slow varying, may be estimated with different estimation techniques. On the other hand, if it is close to or smaller than the symbol duration, the channel is considered to be fast fading (also known as time selective fading). In general, it is difficult to estimate the channel parameters in a fast fading channel (Fig.1)

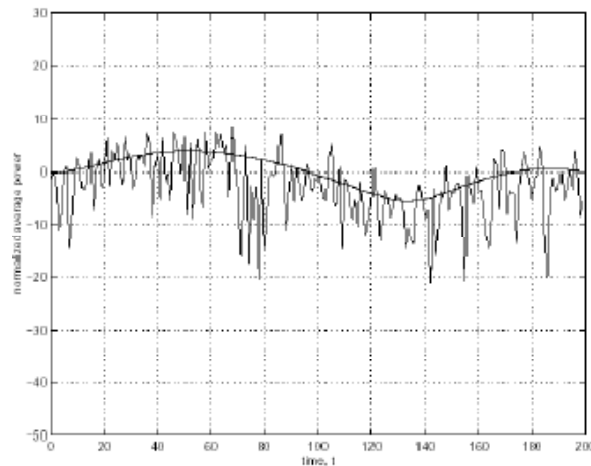

Figure 1. Slow fading versus fast fading

2.2 Fading Channels

The above classification of a fading channel depends on the properties of the transmitted signal. The two ways of classification give rise to four different types of channel: [7]

- Frequency non-selective slow fading
- Frequency selective slow fading
- Frequency non-selective fast fading
- Frequency selective fast fading

3. DIVERSITY

Diversity is the technique used in wireless communications systems to improve the performance over a fading radio channel. Here receiver is provided with multiple copies of the same information signal which are transmitted over two or more real or virtual communication channels. Thus the basic idea of diversity is repetition or redundancy of information. In virtually all the applications, the diversity decisions are made by the receiver and are unknown to the transmitter.

3.1 Types of Diversity

Small-scale fades are characterized by deep and rapid amplitude fluctuations which occur as the mobile moves over distances of just a few wavelengths. For narrow-band signals, this typically results in a Rayleigh faded envelope. In order to prevent deep fades from occurring, *microscopic diversity* techniques can exploit the rapidly changing signal.

Large scale fading, caused due to shadowing, can be combated using *macroscopic diversity* wherein the distances of consideration are of the order of the distances between two base stations.

3.2 Diversity techniques

Diversity techniques are effective when the branches considered are assumed to be independently faded or the envelopes are uncorrelated.

There are mainly five techniques of diversity practically used: [8]

3.2.1. Frequency Diversity

The same information signal is transmitted on different carriers, the frequency separation between them being at least the coherence bandwidth.

3.2.2. Time Diversity

The information signal is transmitted repeatedly in time at regularly intervals. The separation between the transmit times should be greater than the coherence time, T_c . The time interval depends on the fading rate, and increases with the decrease in the rate of fading.

3.2.3. Space Diversity

In Space diversity, there are multiple receiving antennas placed at different spatial locations, resulting in different (possibly independent) received signals.

3.2.4. Polarization diversity

Here, the electric and magnetic fields of the signal carrying the information are modified and many such signals are used to send the same information. Thus orthogonal type of polarization is obtained. It enables detection of smaller radar cross-section (RCS) targets, and avoids the physical, mathematical, and engineering challenges of time-of-arrival coherent combining. The advantage of polarization diversity over spatial diversity is that diversity gains are possible with collocated antennas.

3.2.5 Angle Diversity

The angular diversity schemes may be applied at the base station or at the Mobile unit.

- At the Base station
 - In time Angular Diversity-Combine the two received signals at the same time in order to achieve Diversity Gain. It is a microscopic diversity.
 - Out of time Angular Diversity-The signal strength of the mobile unit is constantly monitored at the base station by each beam of a multi-beam antenna system. The strongest beam is used for the traffic link at the time.

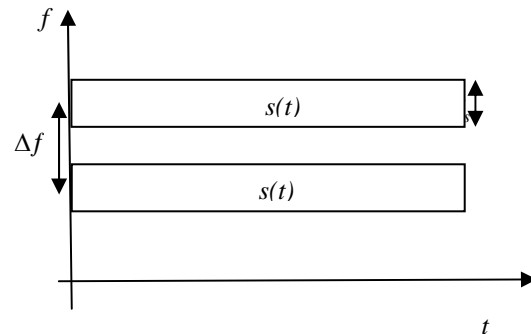

Figure 2. Frequency Diversity

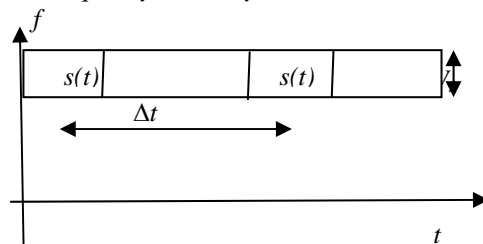

Figure 3. Time Diversity

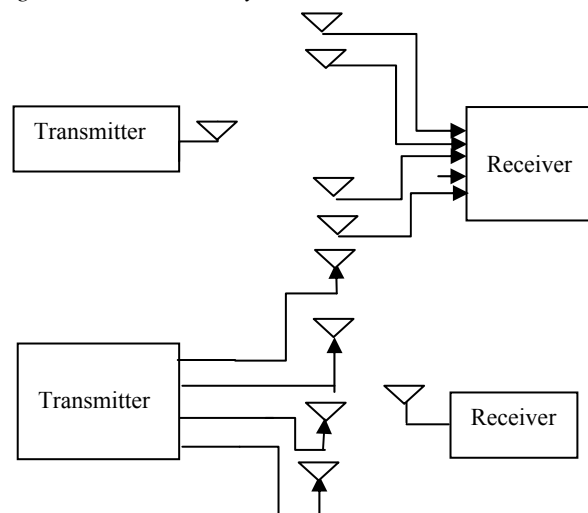

Figure 4. Space Diversity: 1 Tr -N Rr and N Tr-1 Rr Antennas

- At the Mobile unit-If the received signal arrives at the Antenna via several paths, each with a different angle of arrival, the signal components can be isolated by means of directive antennas. Each directive antenna will isolate a different angular component and signals received from different directive antennas are uncorrelated.

Here, directional antennas are used to create independent copies of the transmitted signal over multiple paths.

4. COMBINING METHODS

The idea of diversity is to combine several copies of the transmitted signal, which undergo independent fading, to increase the overall received power. Different types of diversity call for different combining methods. Here, we review several common diversity combining methods.

4.1 Selective Combining for Macroscopic Diversity

In Macroscopic diversity only the local means of the received signal are considered the mean may vary as a result of as a result of long term fading. Selective diversity combining is chosen to primarily reduce long term fading. It is because of the fact that by combining two signals received from different sited transmitting antennas the local means of the two signals at any given time interval are rarely the same.

Assume that there are [7] M different signals obtained, by using a macroscopic diversity scheme and the local mean of the kth signal, $m_k(t)$ is expressed in decibals and denoted by $\omega_k(t)$. The k signals are distinguishable during reception either by their frequency, their angle of arrival, or their time-division multiplexing differences, which are detectable. $\omega_k(t)$ has a lognormal distribution and the probability that the local mean in dBs, $\omega_k(t)$, is less than a level A, in dBs, is :

$$P(\omega_k(t) \leq A) = \int_{-\infty}^A \frac{1}{\sqrt{2\pi\sigma_{\omega_k}^2}} \exp\left[-\frac{(\omega_k - \mu_{\omega_k})^2}{2\sigma_{\omega_k}^2}\right] d\omega_k \quad (1)$$

$$= \frac{1}{2} + \frac{1}{2} \operatorname{erf}\left(\frac{A - \mu_{\omega_k}}{2\sigma_{\omega_k}}\right) \quad (2)$$

Where μ_{ω_k} and σ_{ω_k} are the mean and the standard deviation in decibals of the long term signal $\omega_k(t)$.

If all long term signals are uncorrelated, then the probability that a selectively combined long-term signal $\omega(t)$ will be less than a level A is as follows:

$$P(\omega(t) \leq A) = \prod_{k=1}^M P(\omega_k(t) \leq A) \quad (3)$$

4.2 Combining Techniques for Microscopic Diversity

Microscopic Diversity deals with short term fading. In this case the principle is to obtain a number of signals with equal mean power through the use of diversity schemes. Three types of linear diversity combining schemes are popular:

1. Selective Combining
2. Maximum Ratio Combining
3. Equal Gain Combining

4.2.1 Selective Combining

The algorithm for selective diversity combining is based on the principle of selecting the best signal among all of the signals received from different branches, at the receiver end.[7]

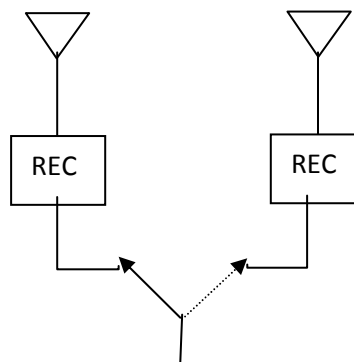

Figure 5. Selective Combining

Consider M branches assuming that the signal to noise ratio achieved on each branch is γ_i ($i=1,$

2..M). Further, assume that the received signal on each branch is independent and Rayleigh distributed with mean power of $2\sigma^2$. Each of γ_i are distributed exponentially.

The pdf of γ_i is given by

$$P(\gamma_i) = (1/\gamma_0) \exp(-\gamma_i/\gamma_0) \quad (4)$$

Where $i=1,2,\dots,M$, $\gamma_i \geq 0$ and $\gamma_0 = 2\sigma^2(E_b/N_0)$ is the mean Signal to Noise ratio. E_b/N_0 is the mean Signal to Noise ratio without fading.

The CDF of SNR is thus

$$P\{\gamma_i \leq \gamma\} = \int_0^\gamma p(x) dx = 1 - \exp\left(-\frac{\gamma}{\gamma_0}\right) \quad (5)$$

The combining method is by picking the $\max_i(\gamma_i)$. The probability that the selected SNR of the branch is less than γ is $P(\gamma) = P_\gamma(\max_i \gamma_i \leq \gamma)$

$$= P_\gamma(\gamma_1 \leq \gamma, \gamma_2 \leq \gamma, \gamma_3 \leq \gamma, \dots, \gamma_M \leq \gamma) = \prod_{i=1}^M (1 - \exp(-\gamma/\gamma_0)) \quad (6)$$

Or

$$P(\gamma) = (1 - \exp(-\gamma/\gamma_0))^M \quad (7)$$

The performance of diversity systems is usually measure by comparing the CDFs of various combining methods.

The main handicap of selection diversity is that the signals must be monitored at a rate faster than that of the fading process if the largest of them all is to be selected.

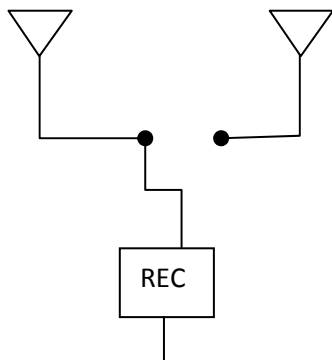

Figure 6. Switched Combining

4.2.2 Switched Combining Technique

In this technique two diversity signals are selected based on a given threshold level in one receiver. If signal A above a threshold L is selected to receive, it receives until it falls below the level L. Two algorithms are used for switching.[6,8]

- (a) Switched and Stay: In this method, the other signal or branch is always selected when the envelope in the current branch falls below threshold L.
- (b) Switched and examine: Here, the other branch is selected only if that SNR is above the threshold L.

The advantage of the scheme is simplicity in implementation as only one receiver front end is required and can be used in mobile units.

4.2.3 Maximum Ratio Combining (MRC)

In MRC, all the branches are used simultaneously. Each of the branch signals is weighted with a gain factor proportional to its own SNR. Co-phasing and summing is done for adding up the weighted branch signals in phase.

The gain associated with the i^{th} branch is decided by the SNR of the corresponding branch. i.e.,

$$\alpha_i = (S/N)_i \quad (8)$$

The MRC scheme requires that the signals be added up after bringing them to the same phase, If a_i is the signal envelope, in each branch then the combined signal envelope is given as

$$a = \sum_{i=1}^M a_i \alpha_i \quad (9)$$

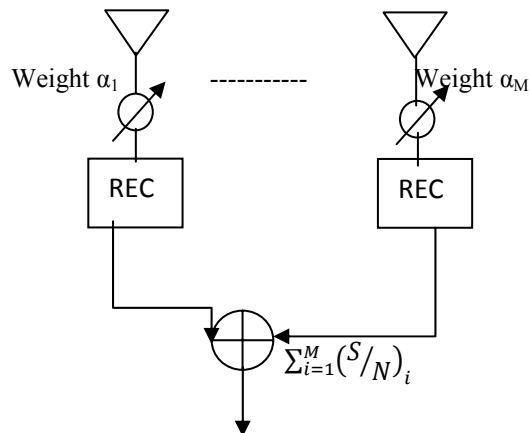

Figure 7. Maximum Ratio Combining

Assuming that the noise components in the channel are independent and identically distributed in each branch, total noise power is

$$N_i = N_0 \sum_{i=1}^M \alpha_i^2 \quad (10)$$

The resulting SNR is thus given by

$$\gamma = \frac{a^2 E_b}{N_0} = \frac{\left(\frac{E_b}{N_0}\right) (\sum \alpha_i a_i)^2}{(\sum \alpha_i^2)^2} \quad (11)$$

Utilizing the Cauchy –Schwarz Inequality,

$$\gamma \leq \left(\frac{E_b}{N_0}\right) (\sum a_i^2) \quad (12)$$

The equation in this case is obtained when $\alpha_i = k \cdot a_i$, k being some constant. The maximum value of the output SNR after MRC is given by

$$\gamma = \left(\frac{E_b}{N_0}\right) (\sum a_i^2) \quad (13)$$

i.e.,

$$\gamma = \sum \left(\frac{E_b}{N_0}\right) a_i^2 = \sum \gamma_i \quad (14)$$

γ_i is χ^2 distributed with degree 2 which is same as exponential distribution.

Let $\gamma = \sum \gamma_i$. Then we can see that γ_i is χ^2 distributed with degree $2M$. Then the pdf of γ is given by

$$P(\gamma) = \frac{1}{(M-1)!} * \frac{\gamma^{M-1}}{\gamma_0^M} * \exp(-\gamma/\gamma_0) \quad (15)$$

With $\gamma \geq 0$;

γ_0 is the mean SNR in each branch and is given by $2\sigma^2 E_b/N_0$.

The CDF of γ is

$$P(\gamma) = \int_0^\gamma \frac{1}{(M-1)!} * \frac{x^{M-1}}{\gamma_0^M} * \exp(-x/\gamma_0) dx \quad (16)$$

$$= 1 - \exp\left(-\frac{\gamma}{\gamma_0}\right) \sum_{i=1}^M \frac{1}{(i-1)!} \left(\frac{\gamma}{\gamma_0}\right)^{i-1} \quad (17)$$

The main challenge in MRC combining is co-phasing of the incoming branches after weighting them.

4.2.4 Equal Gain Combining

It is a co-phase combining that brings all phases to a common point and combines them. The combined signal is the sum of the instantaneous fading envelopes of the individual branches.

Here the gain of every branch α is considered as 1 so for all $i=1,2,\dots,M$ from equation (9)

$$a = \sum_1^M a_i \quad (18)$$

And the resulting SNR is

$$\gamma = a^2 \frac{E_b}{M * N_0} = \left(\frac{E_b}{(M * N_0)}\right) * (\sum a_i^2) \quad (19)$$

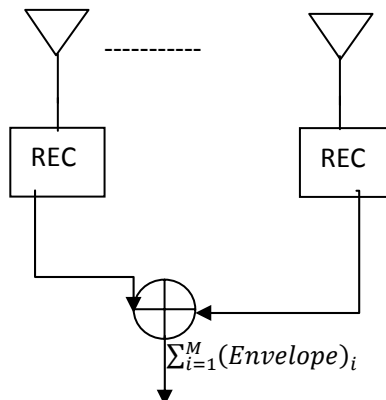

Figure 8. Maximum Ratio Combining

4.3 Combining Techniques for reducing Random Phase

The purpose of this technique is to reduce the random phase in each branch while the signal is being received. It consists of feeding of one or some times two, signals into a single receiving channel, splitting the signal in two by a power divider, and then using a specially designed circuit to combine the two split signals. There are two majors feed combining techniques. [7,8,9]

- Feed Forward Combining and
- Feed Back combining

4.3.1 Feed Forward Combining

A circuit that is used in feed forward combining is shown in the fig. 9. [9]

-Use of nonpilot signal. In this case only one signal is received. In fig. 9 C_1 is a narrowband band pass filter and C_2 is a normal band pass filter. Here the Rayleigh fading environment is considered. At point 1 input signal is expressed as

$$s_1 = r(t) e^{j[\omega_c t + \Psi_s(t) + \Psi_r(t) + \Psi_n(t)]} \quad (20)$$

Where $r(t)$ is the Rayleigh fading component, Ψ_r is the random phase caused by multipath fading, Ψ_n is the random phase caused by system noise, Ψ_s is the message information.

At point 2 and 3 the signal is

$$s_2 = s_2 = \left(\frac{r(t)}{\sqrt{2}}\right) * e^{j[\omega_c t + \Psi_r + \Psi_s + \Psi_n]} \quad (21)$$

At point 4

$$\begin{aligned}
 s_4 &= \frac{r(t)}{\sqrt{2}} \\
 & * \{ \exp[j(\omega_0 t + \alpha)] + j(\omega_c t + \Psi_r + \Psi_s + \Psi_n) \} \\
 & + \exp[j(\omega_0 t + \alpha) - j(\omega_c t + \Psi_r + \Psi_s + \Psi_n)] \} \quad (22)
 \end{aligned}$$

The bandwidth of the C_1 filter is $2\Delta f$ centered at $f_0 - f_c$. If Ψ_s contains voice information then Ψ_s is in the range of 300 to 3000 Hz and $\Delta f = 100$ Hz based on maximum Doppler freq (100 Hz) at the mobile speed of 112 Km /hr at the freq of 850 MHz.

The filtered signal at point 5 is

$$s_5 = K(r(t)/\sqrt{2}) * e^{j[\omega_0 t - \omega_c t + \alpha - \Psi_r - \Psi_n]} \quad (23)$$

Where Ψ_n is the average noise power over the range of 0-100 Hz which is negligible.

At point 6 amplifier of gain A is used hence the signal at point 6 becomes

$$s_6 = KA(r(t)/\sqrt{2}) * e^{j[\omega_0 t - \omega_c t + \alpha - \Psi_r]} \quad (24)$$

At point 7 Mixer M_2 provides an output of

$$\begin{aligned}
 s_7 &= KA(r^2(t)/2) \\
 & * \{ e^{j[\omega_0 t - \omega_c t + \alpha - \Psi_r]} + j[\omega_c t + \alpha \Psi_r + \Psi_s + \Psi_n] \} \\
 & + e^{j[\omega_0 t - \omega_c t + \alpha - \Psi_r] - j[\omega_c t + \alpha \Psi_r + \Psi_s + \Psi_n]} \} \quad (25)
 \end{aligned}$$

At point 8 , after passing through a band pass filter centered at f_0 , the final signal is

$$s_8 = KA(r^2(t)/2) e^{j[\omega_0 t + \alpha + \Psi_s + \Psi_n]} \quad (26)$$

Where A is the Gain of the Amplifier, α is a constant phase ,The term Ψ_r has been dropped from the equation but the system noise still remain.

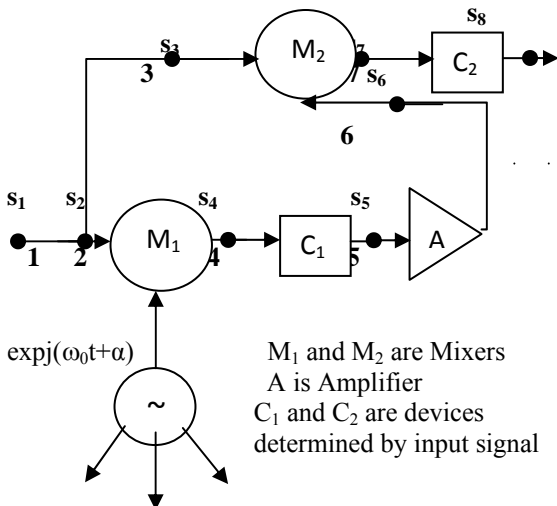

Figure 9. Feed Forward Combining circuits

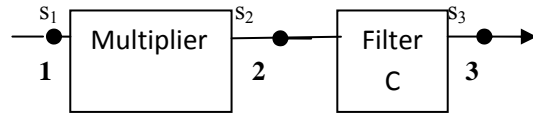

Figure 10. Alternate pilot signaling Method

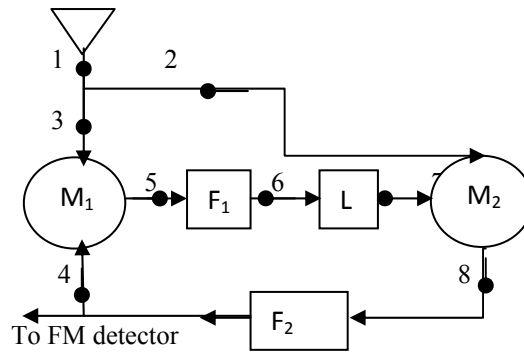

Figure 11. Feedback Combining

-Delayed signal Combining

Here we use the same circuit as shown in fig.9 and till point 4 the signal behaves identical to use of non pilot signal but at 5 the signal characteristics changes since C_1 in this case is a band pass filter followed by a time delay device. The out put of the filter is therefore

$$\begin{aligned}
 s_5 &= \\
 & K(r(t)/\sqrt{2}) * e^{j[\omega_0 t - \omega_c t + \Psi_s(t-\tau) - \Psi_r(t-\tau) + \alpha - \Psi_n(t-\tau)]} \quad (27)
 \end{aligned}$$

At point 8, by following the same steps as were shown for pilot signal combining , the output signal, after passing the amplifier, the mixer and the band pass filter, centered at f_0 is

$$\begin{aligned}
 s_8 &= \\
 & KA \left(\frac{r^2(t)}{2} \right) * \\
 & e^{j[\omega_0 t + \alpha + \Psi_s(t) - (t-\tau) + \Psi_r(t) - \Psi_r(t-\tau) + \Psi_n(t) - \Psi_n(t-\tau)]} \quad (28)
 \end{aligned}$$

If the time delay is small enough relative to the rate of change of, $\Psi_r(t)$, then $\Psi_r(t) - \Psi_r(t-\tau)$ is negligible. Although the term $\Psi_s(t) - \Psi_s(t-\tau)$ is one output phase that indicates the reduction in the FM index, it turns out that the detected signal is not necessarily degraded.[11] The maximum allowable delay τ for this system is roughly $\tau \leq 1/B_c$, B_c being the coherence Band width .When $\tau > 1/B_c$ the delay signal will not contribute to the cancellation of random FM.

-Use of Pilot signal with Communication signal

In this combining scheme two signal communication signal at ω_1 and pilot signal at ω_2 is present.[12]The pilot signal does not carry any information. ω_1 - ω_2 should be within coherence Bandwidth so that the phase term Ψ_r due to random FM within the two signals is almost same, as:

$$\Psi_{r1} \approx \Psi_{r2} \approx \Psi_r \quad (29)$$

The signal at point 1 of Fig. 9 will be

$$s_1 = r_1 e^{j[\omega_1 t + \Psi_r + \Psi_n]} (\text{pilot}) + r_2 e^{j[\omega_2 t + \Psi_s + \Psi_r + \Psi_n]} (\text{signal}) \quad (30)$$

At point 2 and 3, the signal is

$$s_2 = s_1 / \sqrt{2} \quad (31)$$

The final output signal at point assuming that filter C_2 has a band pass of f_0 - f_2 - f_1 , is

$$s_8 = KA \left(\frac{r_1 r_2}{2} \right) * \exp[(\omega_0 - \omega_2 - \omega_1)t + \alpha - \Psi_s] \quad (32)$$

In this case from eqn. (31) it is clear that random FM and system Noise terms are all cancelled.

-Alternate pilot signal method

If we use circuit shown in fig.10 and both signal and pilot is used as input the signal at point 1 will be same as eqn. 30 and at point 2 it will be

$$s_2 = (r_1 e^{\pm j[\omega_1 t + \Psi_r + \Psi_n]} + r_2 e^{\pm j[\omega_2 t + \Psi_s + \Psi_r + \Psi_n]})^2 \quad (33)$$

At point 3 filter C is a band pass filter centered at f_2 - f_1 and the resultant out put signal is

$$s_3 = r_1 r_2 e^{j[(\omega_2 - \omega_1)t + \Psi_s]} \quad (34)$$

The results are approximate results and based on the assumption that the fading information carried by the pilot signal is identical to that carried by communication signal.

4.3.2 Feed Back Combining

It is a pre-detection combining technique that employs feedback as a reference signal in place of a local oscillator as shown in Fig.11.F₁ is a narrow band pass filter centered at f_2 - f_0 and covering $2\Delta f$.F₂ is a band pass filter centered at f_2 .L₁ is a limiting Amplifier and M₁ and M₂ are Mixers. It is also named as Granuled Combiner.

The received in put signal at point 1 is

$$s_1 = r(t) e^{j[\omega_c t + \Psi_s(t) + \Psi_r(t) + \Psi_n(t)]} \quad (35)$$

At point 2 and 3 the signal is divided in two branches hence

$$s_2 = s_3 = s_1 / \sqrt{2} \quad (36)$$

At point 4 the output frequency f_2 from Mixer M₂ with phase α and amplitude A, can be expressed as

$$s_4 = A e^{j(\omega_0 t + \alpha)} \quad (37)$$

The signal at point 4 and 5 after passing through Mixer M₁, the Filter F₁ and the limiting Amplifier, the signal at point 7 – under the conditions that the amplitude variations have been removed by limiting Amplifier L₁ and only the random phase information remains in the signal- is expressed as:

$$s_7 = K e^{j[(\omega_2 - \omega_c)t + \alpha' - \Psi_r(t) - \Psi_n(t)]} \quad (38)$$

Where K is a constant representing the gain of the limiting Amplifier L₁.

At point 8, Mixer M₂ provides an output signal from input signals s_2 and s_7

$$s_8 = \frac{Kr}{\sqrt{2}} e^{j[(\omega_2 - \omega_c)t + \alpha' - \Psi_r(t) - \Psi_n(t)] \pm j[\omega_c t + \Psi_s + \Psi_r + \Psi_n]} \quad (39)$$

At point 4, the final output signal pass through filter F₂ emerges as

$$s_4 = \frac{Kr}{\sqrt{2}} e^{j[\omega_2 t + \alpha' + \Psi_s]} \quad (40)$$

Comparing the phase terms of eqn (37) and (40)

$$\alpha = \alpha' + \Psi_s \quad (41)$$

Since the phase angle of, α' after filtering from F₁ is small compared with Ψ_s hence $\alpha \approx \Psi_s$.

Hence at point 4 the signal becomes

$$s_4 = \frac{Kr}{\sqrt{2}} e^{j[\omega_2 t + \Psi_s]} \quad (42)$$

At point 4 the amplitude of the signal is $Kr/\sqrt{2}$ and the signal $\Psi_s(t)$.

5 DIVERSITY SCHEMES FOR IDMA

In the third generation Wideband Code division Multiple Access (WCDMA) systems the downlink capacity is a bottleneck. Hence transmitter antenna diversity for the down link is proposed[13].Transmit diversity schemes can be divided into two categories :The open loop and the closed loop[2,3]The former sends feed forward or training information, in order to have knowledge of the channel at the transmitter. At the receiver, information is obtained by either linear processing or Maximum Likelihood decoding Techniques. On the other hand the latter has knowledge of the channel at the transmitter by virtue of a feedback path from the receiver to the transmitter. Space Time Transmitter Diversity (STTD) is an example of open loop transmitter antenna Diversity and

Selective Transmitter Diversity(STD) is an example of closed loop system.

The performance of conventional CDMA systems [15] is limited by multiple access interference (MAI), as well as intersymbol interference (ISI). Also, the complexity of CDMA multi-user detection has always been a serious concern. The problem can be seen from the angle of computational cost as well complexity of multi-user detection algorithms. The use of signature sequences for user separation is a characteristic feature for a conventional CDMA system. The possibility of employing interleaving for user separation in CDMA systems is briefly mentioned in [15] but the receiver complexity is considered as a main obstacle.

Now the question arises that what should be the strategy for distinguishing the different users. The possible solutions includes narrow band coded-modulation scheme using trellis codes.

IDMA stands for interleave-division multiple-access (IDMA) scheme used for spread spectrum mobile communication systems, in which users are distinguished by different chip-level interleavers orthogonal in nature instead of by different signatures as in a conventional CDMA system. The scheme considered is a special case of CDMA in which bandwidth expansion is entirely performed by low-rate coding. The spreading operation results bandwidth expansion since a single chip alone can carry one bit of information. Then interleaving is done on each of the data related to individual user. The redundancy from interleaving is introduced mainly to distinguish different users. From a coding theory point of view, however, this is a good choice since it introduces redundancy with coding gain. This scheme inherits many advantages from CDMA such as dynamic channel sharing, mitigation of crosscell interferences, asynchronous transmission, ease of cell planning, and robustness against fading. It also allows a low complexity multiple user detection techniques applicable to systems with large numbers of users in multipath channels.

Since this is also known that one new multiple access technique called IDMA is proposed for future wire less communication system, which is the advanced version of CDMA.

Diversity in IDMA communication system reduce the effect of fading. Beyond third generation and fourth generation (4G) communication systems require bandwidth efficiency and low complexity

receivers to accommodate high data rate and large number of users per cell. IDMA stands out among all the present day multiple access systems. Even if IDMA is a special case of code division multiple access (CDMA), it simply trounces CDMA as far as the cell capacity is concerned. In IDMA, interleavers are used as the only means for user separation. Interleaver size can be varied for a set of users but the recommended interleaver size is 1024 bits at which it provides better efficiency and minimum processing delay. Investigations carried throughout this paper are while using 1024 bit interleavers. IDMA exhibits the tendency to handle huge number of users.

6 CONCLUSION

The diversity is used to provide the receiver with several replicas of the same signal. Diversity techniques are used to improve the performance of the radio channel without any increase in the transmitted power. As higher as the received signal replicas are de-correlated, as much as the diversity gain can be achieved. Different types of Diversity schemes have their own merits and demerits So in different environment different diversity schemes are selected. Combining schemes is also application and environment dependent. interleave-division multiple-access (IDMA) will be the most suitable Multiple access scheme for the Next Generation Wireless networks hence much research is required to improve the performance in terms of Fading too.

REFERENCES:

- [1] Rappaport. D, "Wireless Communications Principles and Practice", Eagle hood Cliffs,NJ:Printice Hall 1996.
- [2] S.M. Alamouti, "A simple transmit diversity technique for wireless communications", IEEE J. Select. Areas Commun. 16 (8) (1998) 1451-1458.
- [3] V.Tarokh, H.Jafarkhani, and A.R. Calderbank, "Space-time block coding for wireless communications: performance result" IEEEJ.selecte.Areas Commun., vol 17, no. 3,Mar. 1999 pp. 451-460,.
- [4] Hafeth Hourani "An Overview of diversity techniques in wireless communication systems" S-72.333 Postgraduate course in radio communication,2004
- [5] DR. Kamilo Fehar,"Wireless Digital Communications-Modulation &Spread

- Spectrum Applications”, Prentice Hall India, 2004.
- [6] William C. Y. Lee , “Mobile Communications Design fundamentals”, Wiley Series in Telecommunications, Second edition,1993.
- [7] William C.Y. Lee , “Mobile Communications Engineering-Theory and Applications”, Second edition, Tata Mc- Graw Hill Publishing company limited, New Delhi,2008.
- [8] M.,K. Simon, M.,S. Alouni, “A Unified Approach to the Performance Analysis of Digital Communication over generalized Fading Channels” , Proc. IEEE 86(9) ,1998,pp 1860-1877.
- [9] M., K. Simon, and M., S. Alouini, “Digital Communication Over Fading Channels: A Unified Approach to Performance Analysis”, Wiley, New York 2000.
- [10] M.Shukla, Asheesh Shukla, Rohit Kumar, V.K.Srivastava, S.Tiwari, “Simple Diversity schemes for IDMA Communication systems” ,International Journal of Applied Engineering Research,vol.4.No 6, June 2009,pp 877-883.
- [11] F.R.Shirley, “FM Suppression in a Mix-On-Self –Loop,”IEEE Trans. Veh. Tech.,vol. 20, no . 4, Dec 1965, pp 471-475.
- [12] W.C Jakes,Microwave Mobile Communications , Wiley New York 1974, pp. 417-426.
- [13] A. Correia, “Transmit Diversity Schemes for WCDMA”, Wireless Personal Communications, 25: 2003, pp 65-85.
- [14] M. Moher and P. Guinand, "An iterative algorithm for asynchronous coded multi-user detection," IEEE Commun. Lett., vol. 2, Aug. 1998, pp. 229-231.
- [15] A.,Basharat, I.A., Khokhar, S., Murtaza, “CDMA versus IDMA for subscriber cell density” , International Conference on ,Innovations in Information Technology, 2008. 16-18 Dec. 2008,pp 520 - 524